

0.1Q2	C	Steep	6	Oceanside	0.07
0.1Q2	D	Flat	3	Oceanside	0.07
0.1Q2	D	Moderate	3	Oceanside	0.07
0.1Q2	D	Steep	3	Oceanside	0.07
0.1Q2	A	Flat	18	Lake Wohlford	0.11
0.1Q2	A	Moderate	18	Lake Wohlford	0.11
0.1Q2	A	Steep	18	Lake Wohlford	0.105
0.1Q2	B	Flat	18	Lake Wohlford	0.09
0.1Q2	B	Moderate	18	Lake Wohlford	0.085
0.1Q2	B	Steep	18	Lake Wohlford	0.085
0.1Q2	C	Flat	6	Lake Wohlford	0.065
0.1Q2	C	Moderate	6	Lake Wohlford	0.065
0.1Q2	C	Steep	6	Lake Wohlford	0.065
0.1Q2	D	Flat	3	Lake Wohlford	0.06
0.1Q2	D	Moderate	3	Lake Wohlford	0.06
0.1Q2	D	Steep	3	Lake Wohlford	0.06

**Table G.2-5: Sizing Factors for Hydromodification Flow Control Biofiltration BMPs Designed Using Sizing Factor Method**

Lower Flow Threshold	Soil Group	Slope	Rain Gauge	A
0.1Q2	A	Flat	Lindbergh	0.32
0.1Q2	A	Moderate	Lindbergh	0.3
0.1Q2	A	Steep	Lindbergh	0.285
0.1Q2	B	Flat	Lindbergh	0.105
0.1Q2	B	Moderate	Lindbergh	0.1
0.1Q2	B	Steep	Lindbergh	0.095
0.1Q2	C	Flat	Lindbergh	0.055
0.1Q2	C	Moderate	Lindbergh	0.05
0.1Q2	C	Steep	Lindbergh	0.05
0.1Q2	D	Flat	Lindbergh	0.05
0.1Q2	D	Moderate	Lindbergh	0.05
0.1Q2	D	Steep	Lindbergh	0.05
0.1Q2	A	Flat	Oceanside	0.15
0.1Q2	A	Moderate	Oceanside	0.14
0.1Q2	A	Steep	Oceanside	0.135

0.1Q2	B	Flat	Oceanside	0.085
0.1Q2	B	Moderate	Oceanside	0.085
0.1Q2	B	Steep	Oceanside	0.085
0.1Q2	C	Flat	Oceanside	0.075
0.1Q2	C	Moderate	Oceanside	0.075
0.1Q2	C	Steep	Oceanside	0.075
0.1Q2	D	Flat	Oceanside	0.07
0.1Q2	D	Moderate	Oceanside	0.07
0.1Q2	D	Steep	Oceanside	0.07
0.1Q2	A	Flat	Lake Wohlford	0.285
0.1Q2	A	Moderate	Lake Wohlford	0.275
0.1Q2	A	Steep	Lake Wohlford	0.27
0.1Q2	B	Flat	Lake Wohlford	0.15
0.1Q2	B	Moderate	Lake Wohlford	0.145
0.1Q2	B	Steep	Lake Wohlford	0.145
0.1Q2	C	Flat	Lake Wohlford	0.07
0.1Q2	C	Moderate	Lake Wohlford	0.07
0.1Q2	C	Steep	Lake Wohlford	0.07
0.1Q2	D	Flat	Lake Wohlford	0.06
0.1Q2	D	Moderate	Lake Wohlford	0.06
0.1Q2	D	Steep	Lake Wohlford	0.06

Table G.2-6: Sizing Factors for Hydromodification Flow Control Cistern Facilities Designed Using Sizing Factor Method

Lower Flow Threshold	Soil Group	Slope	Rain Gauge	V
0.1Q2	A	Flat	Lindbergh	0.54
0.1Q2	A	Moderate	Lindbergh	0.51
0.1Q2	A	Steep	Lindbergh	0.49
0.1Q2	B	Flat	Lindbergh	0.19
0.1Q2	B	Moderate	Lindbergh	0.18
0.1Q2	B	Steep	Lindbergh	0.18
0.1Q2	C	Flat	Lindbergh	0.11
0.1Q2	C	Moderate	Lindbergh	0.11
0.1Q2	C	Steep	Lindbergh	0.11
0.1Q2	D	Flat	Lindbergh	0.09

0.1Q2	D	Moderate	Lindbergh	0.09
0.1Q2	D	Steep	Lindbergh	0.09
0.1Q2	A	Flat	Oceanside	0.26
0.1Q2	A	Moderate	Oceanside	0.25
0.1Q2	A	Steep	Oceanside	0.25
0.1Q2	B	Flat	Oceanside	0.16
0.1Q2	B	Moderate	Oceanside	0.16
0.1Q2	B	Steep	Oceanside	0.16
0.1Q2	C	Flat	Oceanside	0.14
0.1Q2	C	Moderate	Oceanside	0.14
0.1Q2	C	Steep	Oceanside	0.14
0.1Q2	D	Flat	Oceanside	0.12
0.1Q2	D	Moderate	Oceanside	0.12
0.1Q2	D	Steep	Oceanside	0.12
0.1Q2	A	Flat	Lake Wohlford	0.53
0.1Q2	A	Moderate	Lake Wohlford	0.49
0.1Q2	A	Steep	Lake Wohlford	0.49
0.1Q2	B	Flat	Lake Wohlford	0.28
0.1Q2	B	Moderate	Lake Wohlford	0.28
0.1Q2	B	Steep	Lake Wohlford	0.28
0.1Q2	C	Flat	Lake Wohlford	0.14
0.1Q2	C	Moderate	Lake Wohlford	0.14
0.1Q2	C	Steep	Lake Wohlford	0.14
0.1Q2	D	Flat	Lake Wohlford	0.12
0.1Q2	D	Moderate	Lake Wohlford	0.12
0.1Q2	D	Steep	Lake Wohlford	0.12

Placeholder – **Vector Control Plan** (required when structural BMPs will drain in 96 hours)

Replace placeholder with required documentation.

Leave placeholder intact if not applicable.

Not Applicable



**ATTACHMENT 3**  
**STRUCTURAL BMP MAINTENANCE INFORMATION**

This is the cover sheet for Attachment 3.



**Indicate which Items are Included:**

Attachment Sequence	Contents	Checklist
Attachment 3a	Structural BMP Maintenance Thresholds and Actions (Required)	<input checked="" type="checkbox"/> Included  See Structural BMP Maintenance Information Checklist.
Attachment 3b	Draft Maintenance Agreement (when applicable)	<input type="checkbox"/> Included <input checked="" type="checkbox"/> Not Applicable (will be provided during Final Design)

PRELIMINARY MAINTENANCE INFORMATION IS INCLUDED FOR THIS CONCEPTUAL DESIGN PHASE TO SUPPORT ENTITLEMENTS ONLY. ADDITIONAL MAINTENANCE INFORMATION AND MAINTENANCE AGREEMENT WILL BE PROVIDED AT FINAL DESIGN / MINESTERIAL PERMITS.



**Use this checklist to ensure the required information has been included in the Structural BMP Maintenance Information Attachment:**

**Preliminary Design / Planning / CEQA level submittal:**

- Attachment 3a must identify:
  - Typical maintenance indicators and actions for proposed structural BMP(s) based on Section 7.7 of the BMP Design Manual
- Attachment 3b is not required for preliminary design / planning / CEQA level submittal.

**Final Design level submittal:**

Attachment 3a must identify:

- Specific maintenance indicators and actions for proposed structural BMP(s). This shall be based on Section 7.7 of the BMP Design Manual and enhanced to reflect actual proposed components of the structural BMP(s)
- How to access the structural BMP(s) to inspect and perform maintenance
- Features that are provided to facilitate inspection (e.g., observation ports, cleanouts, silt posts, or other features that allow the inspector to view necessary components of the structural BMP and compare to maintenance thresholds)
- Manufacturer and part number for proprietary parts of structural BMP(s) when applicable
- Maintenance thresholds specific to the structural BMP(s), with a location-specific frame of reference (e.g., level of accumulated materials that triggers removal of the materials, to be identified based on viewing marks on silt posts or measured with a survey rod with respect to a fixed benchmark within the BMP)
- Recommended equipment to perform maintenance
- When applicable, necessary special training or certification requirements for inspection and maintenance personnel such as confined space entry or hazardous waste management

Attachment 3b: For private entity operation and maintenance, Attachment 3b shall include a draft maintenance agreement in the local jurisdiction's standard format (PDP applicant to contact the City Engineer to obtain the current maintenance agreement forms).





# Inspection Guidelines for Modular Wetland System - Linear

## Inspection Summary

- Inspect Pre-Treatment, Biofiltration and Discharge Chambers – average inspection interval is 6 to 12 months.
  - *(15 minute average inspection time).*
- **NOTE:** Pollutant loading varies greatly from site to site and no two sites are the same. Therefore, the first year requires inspection monthly during the wet season and every other month during the dry season in order to observe and record the amount of pollutant loading the system is receiving.

## System Diagram

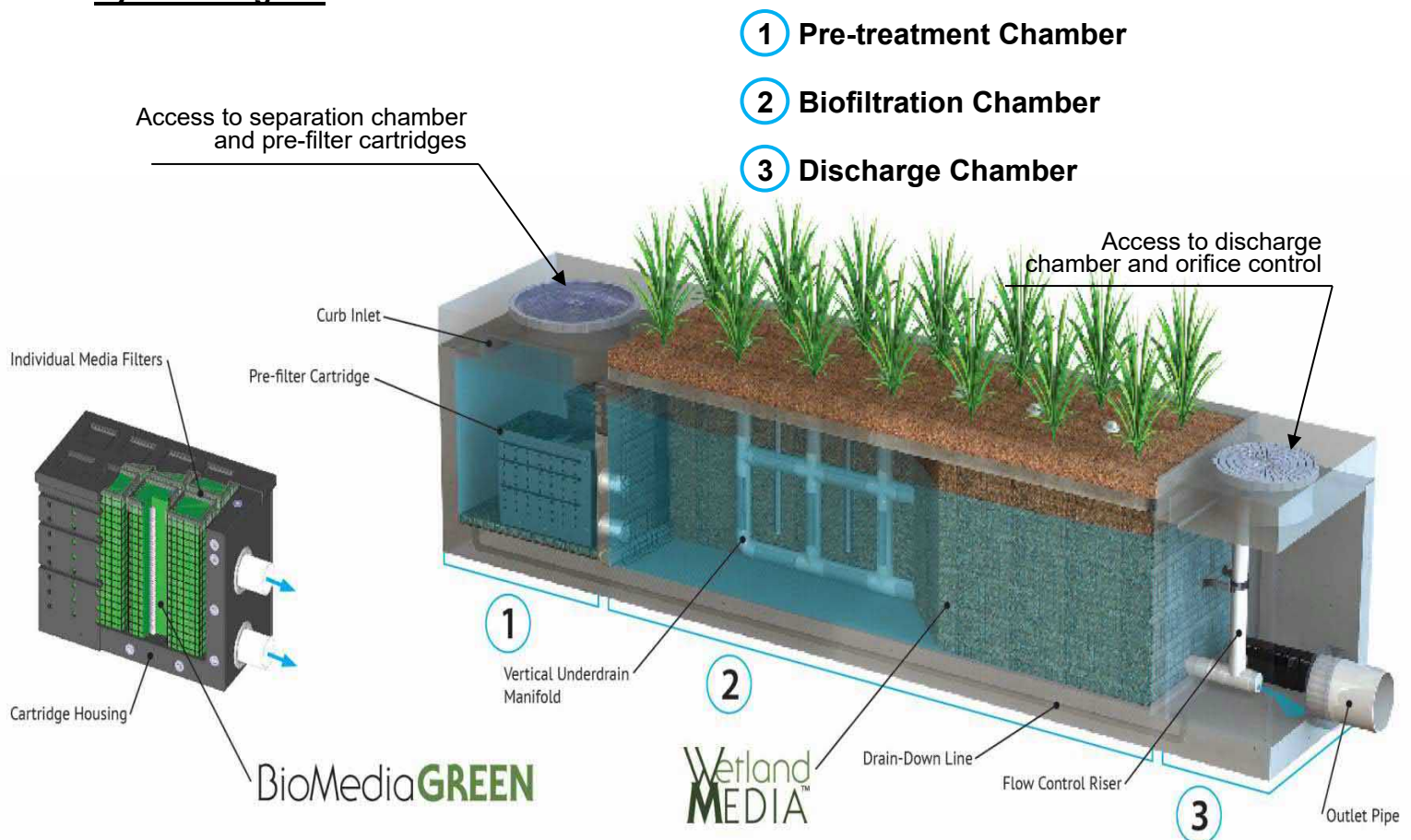

## Inspection Overview

As with all stormwater BMPs inspection and maintenance on the MWS Linear is necessary. Stormwater regulations require that all BMPs be inspected and maintained to ensure they are operating as designed to allow for effective pollutant removal and provide protection to receiving water bodies. It is recommended that inspections be performed multiple times during the first year to assess the site specific loading conditions. This is recommended because pollutant loading and pollutant characteristics can vary greatly from site to site. Variables such as nearby soil erosion or construction sites, winter sanding on roads, amount of daily traffic and land use can increase pollutant loading on the system. The first year of inspections can be used to set inspection and maintenance intervals for subsequent years to ensure appropriate maintenance is provided. Without appropriate maintenance a BMP will exceed its storage capacity which can negatively affect its continued performance in removing and retaining captured pollutants.

### Inspection Equipment

Following is a list of equipment to allow for simple and effective inspection of the MWS Linear:

- Modular Wetland Inspection Form
- Flashlight
- Manhole hook or appropriate tools to remove access hatches and covers
- Appropriate traffic control signage and procedures
- Measuring pole and/or tape measure.
- Protective clothing and eye protection.
- 7/16" open or closed ended wrench.
- **Large permanent black marker (initial inspections only – first year)**
- Note: entering a confined space requires appropriate safety and certification. It is generally not required for routine inspections of the system.





## **Inspection Steps**

The core to any successful stormwater BMP maintenance program is routine inspections. The inspection steps required on the MWS Linear are quick and easy. As mentioned above the first year should be seen as the maintenance interval establishment phase. During the first year more frequent inspections should occur in order to gather loading data and maintenance requirements for that specific site. This information can be used to establish a base for long term inspection and maintenance interval requirements.

The MWS Linear can be inspected through visual observation without entry into the system. All necessary pre-inspection steps must be carried out before inspection occurs, especially traffic control and other safety measures to protect the inspector and near-by pedestrians from any dangers associated with an open access hatch or manhole. Once these access covers have been safely opened the inspection process can proceed:

- Prepare the inspection form by writing in the necessary information including project name, location, date & time, unit number and other info (see inspection form).
- Observe the inside of the system through the access hatches. If minimal light is available and vision into the unit is impaired utilize a flashlight to see inside the system and all of its chambers.
- Look for any out of the ordinary obstructions in the inflow pipe, pre-treatment chamber, biofiltration chamber, discharge chamber or outflow pipe. Write down any observations on the inspection form.
- Through observation and/or digital photographs estimate the amount of trash, debris and sediment accumulated in the pre-treatment chamber. Utilizing a tape measure or measuring stick estimate the amount of trash, debris and sediment in this chamber. Record this depth on the inspection form.

- Through visual observation inspect the condition of the pre-filter cartridges. Look for excessive build-up of sediments on the cartridges, any build-up on the top of the cartridges, or clogging of the holes. Record this information on the inspection form. The pre-filter cartridges can further be inspected by removing the cartridge tops and assessing the color of the BioMediaGREEN filter cubes (requires entry into pre-treatment chamber – see notes above regarding confined space entry). Record the color of the material. New material is a light green in color. As the media becomes clogged it will turn darker in color, eventually becoming dark brown or black. Using the below color indicator record the percentage of media exhausted.

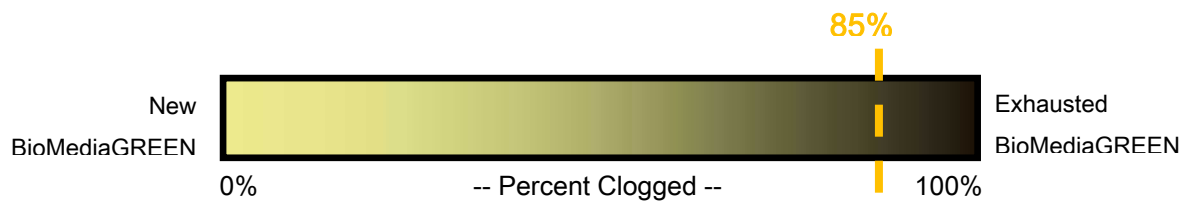

- The biofiltration chamber is generally maintenance free due to the system's advanced pre-treatment chamber. For units which have open planters with vegetation it is recommended that the vegetation be inspected. Look for any plants that are dead or showing signs of disease or other negative stressors. Record the general health of the plants on the inspection and indicate through visual observation or digital photographs if trimming of the vegetation is needed.
- The discharge chamber houses the orifice control structure and is connected to the outflow pipe. It is important to check to ensure the orifice is in proper operating conditions and free of any obstructions. Generally, the discharge chamber will be clean and free of debris. Inspect the water marks on the side walls. If possible, inspect the discharge chamber during a rain event to assess the amount of flow leaving the system while it is at 100% capacity (pre-treatment chamber water level at peak HGL). The water level of the flowing water should be compared to the watermark level on the side walls which is an indicator of the highest discharge rate the system achieved when initially installed. Record on the form if there is any difference in level from watermark in inches.

- NOTE: During the first few storms the water level in the outflow chamber should be observed and a 6" long horizontal watermark line drawn (using a large permanent marker) at the water level in the discharge chamber while the system is operating at 100% capacity. The diagram below illustrates where a line should be drawn. This line is a reference point for future inspections of the system:

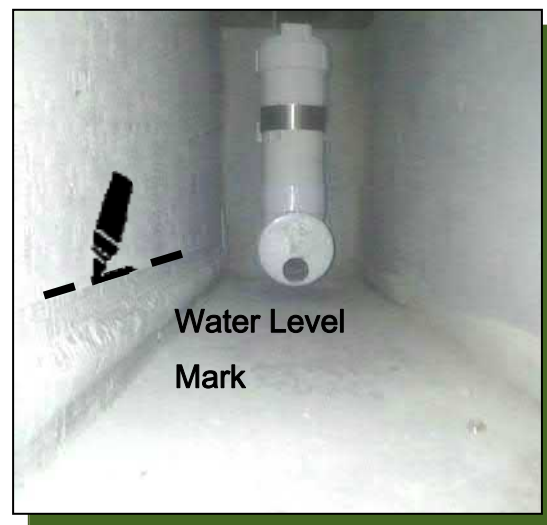

Using a permanent marker draw a 6 inch long horizontal line, as shown, at the higher water level in the MWS Linear discharge chamber.

- Water level in the discharge chamber is a function of flow rate and pipe size. Observation of water level during the first few months of operation can be used as a benchmark level for future inspections. The initial mark and all future observations shall be made when system is at 100% capacity (water level at maximum level in pre-treatment chamber). If future water levels are below this mark when system is at 100% capacity this is an indicator that maintenance to the pre-filter cartridges may be needed.
- Finalize inspection report for analysis by the maintenance manager to determine if maintenance is required.

## **Maintenance Indicators**

Based upon observations made during inspection, maintenance of the system may be required based on the following indicators:

- Missing or damaged internal components or cartridges.
- Obstructions in the system or its inlet or outlet.
- Excessive accumulation of floatables in the pre-treatment chamber in which the length and width of the chamber is fully impacted more than 18”.

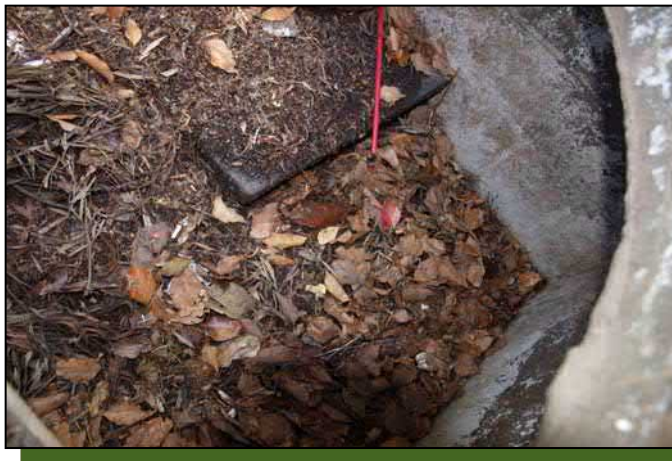

- Excessive accumulation of sediment in the pre-treatment chamber of more than 6” in depth.



- Excessive accumulation of sediment on the BioMediaGREEN media housed within the pre-filter cartridges. The following chart shows photos of the condition of the BioMediaGREEN contained within the pre-filter cartridges. When media is more than 85% clogged replacement is required.



- Overgrown vegetation.



- Water level in discharge chamber during 100% operating capacity (pre-treatment chamber water level at max height) is lower than the watermark by 20%.



## **Inspection Notes**

1. Following maintenance and/or inspection, it is recommended the maintenance operator prepare a maintenance/inspection record. The record should include any maintenance activities performed, amount and description of debris collected, and condition of the system and its various filter mechanisms.
2. The owner should keep maintenance/inspection record(s) for a minimum of five years from the date of maintenance. These records should be made available to the governing municipality for inspection upon request at any time.
3. Transport all debris, trash, organics and sediments to approved facility for disposal in accordance with local and state requirements.
4. Entry into chambers may require confined space training based on state and local regulations.
5. No fertilizer shall be used in the Biofiltration Chamber.
6. Irrigation should be provided as recommended by manufacturer and/or landscape architect. Amount of irrigation required is dependent on plant species. Some plants may not require irrigation after initial establishment.



# Maintenance Guidelines for Modular Wetland System - Linear

## Maintenance Summary

- Remove Sediment from Pre-Treatment Chamber – average maintenance interval is 12 to 24 months.
  - *(10 minute average service time).*
- Replace Pre-Filter Cartridge Media – average maintenance interval 12 to 24 months.
  - *(10-15 minute per cartridge average service time).*
- Trim Vegetation – average maintenance interval is 6 to 12 months.
  - *(Service time varies).*

## System Diagram

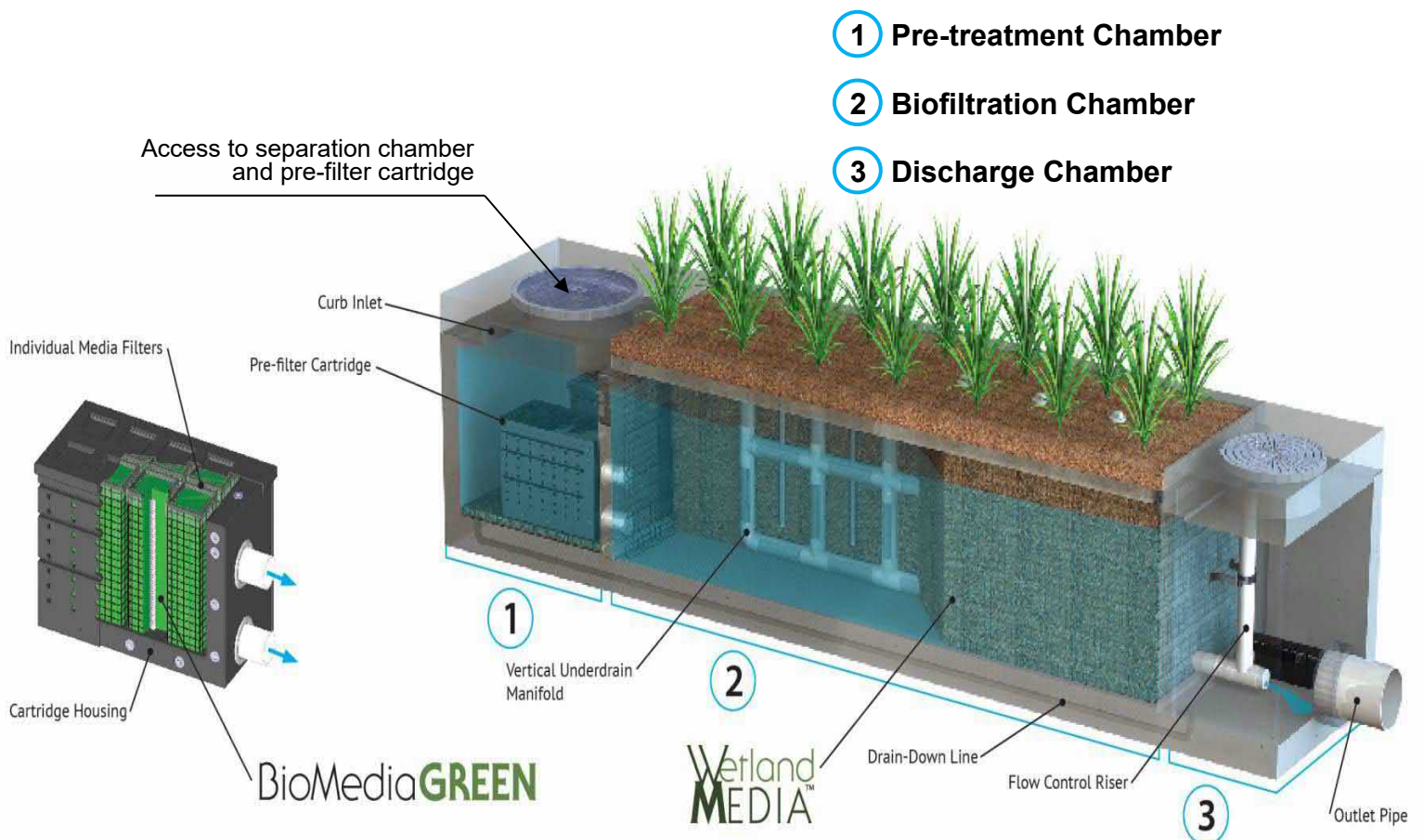

## Maintenance Overview

The time has come to maintain your Modular Wetland System Linear (MWS Linear). To ensure successful and efficient maintenance on the system we recommend the following. The MWS Linear can be maintained by removing the access hatches over the systems various chambers. All necessary pre-maintenance steps must be carried out before maintenance occurs, especially traffic control and other safety measures to protect the inspector and near-by pedestrians from any dangers associated with an open access hatch or manhole. Once traffic control has been set up per local and state regulations and access covers have been safely opened the maintenance process can begin. It should be noted that some maintenance activities require confined space entry. All confined space requirements must be strictly followed before entry into the system. In addition the following is recommended:

- Prepare the maintenance form by writing in the necessary information including project name, location, date & time, unit number and other info (see maintenance form).
- Set up all appropriate safety and cleaning equipment.
- Ensure traffic control is set up and properly positioned.
- Prepare a pre-checks (OSHA, safety, confined space entry) are performed.

### Maintenance Equipment

Following is a list of equipment required for maintenance of the MWS Linear:

- Modular Wetland Maintenance Form
- Manhole hook or appropriate tools to access hatches and covers
- Protective clothing, flashlight and eye protection.
- 7/16" open or closed ended wrench.
- Vacuum assisted truck with pressure washer.
- Replacement BioMediaGREEN for Pre-Filter Cartridges if required (order from manufacturer).



## Maintenance Steps

1. Pre-treatment Chamber (bottom of chamber)
  - A. Remove access hatch or manhole cover over pre-treatment chamber and position vacuum truck accordingly.
  - B. With a pressure washer spray down pollutants accumulated on walls and pre-filter cartridges.
  - C. Vacuum out Pre-Treatment Chamber and remove all accumulated pollutants including trash, debris and sediments. Be sure to vacuum the floor until pervious pavers are visible and clean.
  - D. If Pre-Filter Cartridges require media replacement move onto step 2. If not, replace access hatch or manhole cover.



Removal of access hatch to gain access below.



Insertion of vacuum hose into separation chamber.



Removal of trash, sediment and debris.



Fully cleaned separation chamber.

2. Pre-Filter Cartridges (attached to wall of pre-treatment chamber)

- A. After finishing step 1 enter pre-treatment chamber.
- B. Unscrew the two bolts holding the lid on each cartridge filter and remove lid.



Pre-filter cartridges with tops on.



Inside cartridges showing media filters ready for replacement.

- C. Place the vacuum hose over each individual media filter to suck out filter media.



Vacuuming out of media filters.

- D. Once filter media has been sucked use a pressure washer to spray down inside of the cartridge and it's containing media cages. Remove cleaned media cages and place to the side. Once removed the vacuum hose can be inserted into the cartridge to vacuum out any remaining material near the bottom of the cartridge.

- E. Reinstall media cages and fill with new media from manufacturer or outside supplier. Manufacturer will provide specification of media and sources to purchase. Utilize the manufacture provided refilling tray and place on top of cartridge. Fill tray with new bulk media and shake down into place. Using your hands slightly compact media into each filter cage. Once cages are full removed refilling tray and replace cartridge top ensuring bolts are properly tightened.



Refilling tray for media replacement.



Refilling tray on cartridge with bulk media.



- F. Exit pre-treatment chamber. Replace access hatch or manhole cover.

### 3. Biofiltration Chamber (middle vegetated chamber)

- A. In general, the biofiltration chamber is maintenance free with the exception of maintaining the vegetation. Using standard gardening tools properly trim back the vegetation to healthy levels. The MWS Linear utilizes vegetation similar to surrounding landscape areas therefore trim vegetation to match surrounding vegetation. If any plants have died replace plants with new ones:





## **Inspection Notes**

1. Following maintenance and/or inspection, it is recommended the maintenance operator prepare a maintenance/inspection record. The record should include any maintenance activities performed, amount and description of debris collected, and condition of the system and its various filter mechanisms.
2. The owner should keep maintenance/inspection record(s) for a minimum of five years from the date of maintenance. These records should be made available to the governing municipality for inspection upon request at any time.
3. Transport all debris, trash, organics and sediments to approved facility for disposal in accordance with local and state requirements.
4. Entry into chambers may require confined space training based on state and local regulations.
5. No fertilizer shall be used in the Biofiltration Chamber.
6. Irrigation should be provided as recommended by manufacturer and/or landscape architect. Amount of irrigation required is dependent on plant species. Some plants may not require irrigation after initial establishment.



## Inspection Form



**Modular Wetland System, Inc.**

**P. 760.433-7640**

**F. 760-433-3176**

**E. [Info@modularwetlands.com](mailto:Info@modularwetlands.com)**

**[www.modularwetlands.com](http://www.modularwetlands.com)**



# Inspection Report Modular Wetlands System



Project Name \_\_\_\_\_

Project Address \_\_\_\_\_ (city) (Zip Code)

Owner / Management Company \_\_\_\_\_

Contact \_\_\_\_\_ Phone ( ) -

Inspector Name \_\_\_\_\_ Date \_\_\_\_ / \_\_\_\_ / \_\_\_\_ Time \_\_\_\_\_ AM / PM

Type of Inspection  Routine  Follow Up  Complaint  Storm Storm Event in Last 72-hours?  No  Yes

Weather Condition \_\_\_\_\_ Additional Notes \_\_\_\_\_

For Office Use Only

---

(Reviewed By) \_\_\_\_\_

---

(Date) \_\_\_\_\_  
Office personnel to complete section to the left.

### Inspection Checklist

Modular Wetland System Type (Curb, Grate or UG Vault): \_\_\_\_\_ Size (22', 14' or etc.): \_\_\_\_\_

Structural Integrity:	Yes	No	Comments
Damage to pre-treatment access cover (manhole cover/grate) or cannot be opened using normal lifting pressure?			
Damage to discharge chamber access cover (manhole cover/grate) or cannot be opened using normal lifting pressure?			
Does the MWS unit show signs of structural deterioration (cracks in the wall, damage to frame)?			
Is the inlet/outlet pipe or drain down pipe damaged or otherwise not functioning properly?			
<b>Working Condition:</b>			
Is there evidence of illicit discharge or excessive oil, grease, or other automobile fluids entering and clogging the unit?			
Is there standing water in inappropriate areas after a dry period?			
Is the filter insert (if applicable) at capacity and/or is there an accumulation of debris/trash on the shelf system?			
Does the depth of sediment/trash/debris suggest a blockage of the inflow pipe, bypass or cartridge filter? If yes, specify which one in the comments section. Note depth of accumulation in in pre-treatment chamber.			Depth:
Does the cartridge filter media need replacement in pre-treatment chamber and/or discharge chamber?			Chamber:
Any signs of improper functioning in the discharge chamber? Note issues in comments section.			
<b>Other Inspection Items:</b>			
Is there an accumulation of sediment/trash/debris in the wetland media (if applicable)?			
Is it evident that the plants are alive and healthy (if applicable)? Please note Plant Information below.			
Is there a septic or foul odor coming from inside the system?			

Waste:	Yes	No
Sediment / Silt / Clay		
Trash / Bags / Bottles		
Green Waste / Leaves / Foliage		

Recommended Maintenance	
No Cleaning Needed	
Schedule Maintenance as Planned	
Needs Immediate Maintenance	

Plant Information	
Damage to Plants	
Plant Replacement	
Plant Trimming	

Additional Notes: \_\_\_\_\_



## Maintenance Report

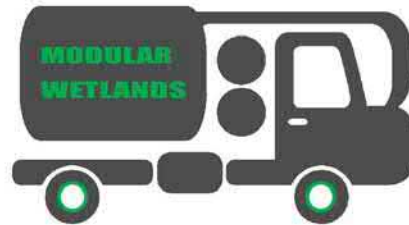

**Modular Wetland System, Inc.**

**P. 760.433-7640**

**F. 760-433-3176**

**E. [Info@modularwetlands.com](mailto:Info@modularwetlands.com)**

**[www.modularwetlands.com](http://www.modularwetlands.com)**



# Cleaning and Maintenance Report Modular Wetlands System



Project Name \_\_\_\_\_

Project Address \_\_\_\_\_ (city) (Zip Code)

Owner / Management Company \_\_\_\_\_

Contact \_\_\_\_\_ Phone ( ) -

Inspector Name \_\_\_\_\_ Date \_\_\_\_ / \_\_\_\_ / \_\_\_\_ Time \_\_\_\_ AM / PM

Type of Inspection  Routine  Follow Up  Complaint  Storm Storm Event in Last 72-hours?  No  Yes

Weather Condition \_\_\_\_\_ Additional Notes \_\_\_\_\_

For Office Use Only

---

(Reviewed By) \_\_\_\_\_

---

(Date) \_\_\_\_\_  
Office personnel to complete section to the left.

Site Map #	GPS Coordinates of Insert	Manufacturer / Description / Sizing	Trash Accumulation	Foliage Accumulation	Sediment Accumulation	Total Debris Accumulation	Condition of Media 25/50/75/100 (will be changed @ 75%)	Operational Per Manufactures' Specifications (If not, why?)
	Lat: Long:	MWS Catch Basins						
		MWS Sedimentation Basin						
		Media Filter Condition						
		Plant Condition						
		Drain Down Media Condition						
		Discharge Chamber Condition						
		Drain Down Pipe Condition						
		Inlet and Outlet Pipe Condition						

Comments:

---



---



# Cleaning and Maintenance Report Modular Wetlands System



Project Name \_\_\_\_\_

Project Address \_\_\_\_\_ (city) (Zip Code)

Owner / Management Company \_\_\_\_\_

Contact \_\_\_\_\_ Phone ( ) -

Inspector Name \_\_\_\_\_ Date \_\_\_\_ / \_\_\_\_ / \_\_\_\_ Time \_\_\_\_ AM / PM

Type of Inspection  Routine  Follow Up  Complaint  Storm Storm Event in Last 72-hours?  No  Yes

Weather Condition \_\_\_\_\_ Additional Notes \_\_\_\_\_

For Office Use Only

---

(Reviewed By) \_\_\_\_\_

---

(Date) \_\_\_\_\_  
Office personnel to complete section to the left.

Site Map #	GPS Coordinates of Insert	Manufacturer / Description / Sizing	Trash Accumulation	Foliage Accumulation	Sediment Accumulation	Total Debris Accumulation	Condition of Media 25/50/75/100 (will be changed @ 75%)	Operational Per Manufactures' Specifications (If not, why?)
	Lat: Long:	MWS Catch Basins						
		MWS Sedimentation Basin						
		Media Filter Condition						
		Plant Condition						
		Drain Down Media Condition						
		Discharge Chamber Condition						
		Drain Down Pipe Condition						
		Inlet and Outlet Pipe Condition						

Comments:

---



---

## Operation & Maintenance Manual – BIOFILTRATION BMP

### 1. PURPOSE OF THE BIOFILTRATION BMP MAINTENANCE MANUAL

The purpose of this manual is to provide maintenance instructions for the Biofiltration BMPs located within Jefferson Oceanside Project. The Biofiltration basin is a pollution control device designed to treat urban runoff before it enters in to the storm drain systems located on the project site. Regular maintenance will help to ensure that the biofiltration functions as it has been designed.

This manual will serve as a reference guide and filed manual to assist the property owner with:

- An overview of the Biofiltration BMP and how it functions
- A description of the location of the Biofiltration BMP
- An understanding of the procedures required to effectively maintain the Biofiltration BMP on a regular basis
- Reproducible copies of the forms, logs and guidance sheets necessary for recording maintenance activities associated with the Biofiltration BMP.

### 2. GENERAL DESCRIPTION AND FUNCTION OF THE BIOFILTRATION BMP

The Biofiltration BMP is a structure filled with gravel soil and vegetation that drain to an underdrain which connects to the storm drain system. These systems also have an overflow structure to prevent high flows from leaving the planter area. From the top of the curb or concrete step-off to the bottom, the porous materials consist of

#### BMP 1:

- 3" of well-aged shredded mulch
- 18" of Biofiltration Soil Media (BSM)
- 6" Washed Pea Gravel Filter Course Layer
- 12" Open Graded Sub-Base Course rounded #57 Stone, 40% Voids

A 6" diameter perforated pvc underdrain will be installed 3" from the bottom of the open graded sub-base. This pipe connects to the storm drain.

Pollution is mitigated through infiltration of runoff into the porous materials within the planter and ultimately through infiltration through the biofiltration soil media and stone layers.

### 3. MAINTENANCE RESPONSIBILITY

JPI Development Comp will be responsible for Site Design, Source Control and Treatment Control BMPs and is ultimately responsible for maintaining the Biofiltration BMP. The goal in maintaining the planter is to ensure that Infiltration is occurring. Regular inspection and replacement of materials within the planter once it becomes ineffective in performing as designed are the major components in the maintenance program. In order to achieve this, the following general procedures shall be followed:

- Qualified maintenance personnel should periodically inspect the planter at least twice a year. The first inspection should happen prior to August 1 and the subsequent inspection should happen during the period between February 1 and March 31.
- If a problem is identified, it should be rectified as soon as possible to ensure that the trench functions as designed,

- Regular removal of trash and debris should occur as needed. Trash and debris, visible along the surface of the trench shall be promptly removed.

Detailed maintenance procedures are outlined 5.

#### 4. MAINTENANCE INDICATORS AND ACTIVITIES

##### Functional Maintenance:

Regular functional maintenance is required to ensure that the Biofiltration BMP performs in an effective manner. Functional maintenance consists of both preventative and corrective activities. Logs and guidance sheets are contained herein to use in recording vital information while performing operation Inspection and other infiltration trench maintenance activities. Maintenance records shall be maintained by the property owner for a minimum of five years. The proper use and subsequent storage of these records will assure the City of Oceanside that the Biofiltration BMP is functioning as designed.

##### Preventative Maintenance:

Preventative maintenance shall be performed on a regular basis. Checklists are included herein to track and record preventative maintenance activities. These activities include trash and debris removal and sediment management,

Trash and debris removal shall be performed to ensure that runoff has adequate surface area to infiltrate through the various layers that comprise the cross section of the trench.

Sediment management will occur when testing Indicates that the Infiltration rate has diminished below the stated acceptable rate.

##### Corrective Maintenance:

Corrective maintenance will be required on an emergency or non-routine basis to correct problems and restore the intended operation and safe function of the Biofiltration BMP.

### Biofiltration BMP Maintenance

- Inspect a minimum of once per year, before the rainy season, and after large storm events or more frequently as needed.
- Clean the planter when the loss of infiltrative capacity is observed. When the standing water is present for a period of time in excess of 72 hours, removal of sediment may be necessary.
- Control mosquitoes as necessary.
- Remove litter and debris from surface as required.

### Maintenance Indicators:

Maintenance Indicators are signs or triggers that indicate that maintenance personnel need to check the Biofiltration BMP for maintenance needs. The most common triggers include warnings or accounts of standing water and sediment accumulation. Inspection and Maintenance Checklist in Section 5 below shows conditions and criteria that trigger the need for some specific routine infiltration trench maintenance activities. Emergencies may occasionally arise that would require a more urgent, critical response.

### Sediment Management:

The types of storm water pollutants that accumulate in sediment varies, but may include contaminants such as heavy metals, petroleum hydrocarbons, and other organic compounds such as pesticides or solvents. When the sediment has clogged the Biofiltration BMP, remove and properly dispose of Sediment. Regrade if necessary.

### Sediment Disposal:

Several methods for disposal are available depending on the concentration of toxins in the waste. Methods can range from recycling the material, to depositing the sediment into appropriate landfills.

At the time of disposal, if the wastes are deemed to be unfit for disposal in a municipal landfill, a full and comprehensive testing program should be run by a qualified person to test for all the constituents outlined under California code of Regulations (CCR) Title 22. Title 22 list concentrations of certain chemicals and their soluble threshold limit concentrations (STLC's) and their total threshold limit concentrations (TTLC's). Chemicals that exceed the allowable concentrations are considered hazardous wastes and must be removed from the sediment.

## 5. INSPECTION AND MAINTENANCE CHECKLIST

See following page.

## Biofiltration BMP Inspection and Maintenance Checklist

Date of Inspection: \_\_\_\_\_ BMP Name/Location: \_\_\_\_\_ Inspected by: \_\_\_\_\_

Type of Inspection:     Monthly     Pre-Wet Season     After Heavy Runoff (1" or greater)     Annual Prior to Start of Wet Season  
 Other \_\_\_\_\_

Defect	Conditions When Maintenance is Required	Field Measurement	Measurement Frequency	Maintenance Activity	Maintenance Needed (yes/no)	Comments (Describe maintenance completed and if needed maintenance was not conducted, note when it will be done)
Vegetation Management for Aesthetics (optional)	Visual observation and random measurements throughout the side slope area	Visual observation and random measurements throughout the side slope area	Annually, prior to start of wet season	Cut vegetation to an average height of 6-inches and remove trimmings. Remove any trees, or woody vegetation.		
Standing Water	Visual observation	Visual observation	Annually, 96 hours after a target storm (0.60 in) event	Drain facility. Corrective action prior to wet season. Consult engineers if immediate solution is not evident.		
Trash and Debris	Visual observation	Visual observation	Annually, prior to start of wet season	Remove and dispose of trash and debris		
Sediment Management	Measure depth at apparent maximum and minimum accumulation of sediment. Calculate average depth	Measure depth at apparent maximum and minimum accumulation of sediment. Calculate average depth	Annually, prior to start of wet season	Remove and properly dispose of sediment. Regrade if necessary. (expected every 2 years)		
Underdrains	Visual Observation	Visual Observation	Annually, prior to start of wet season	Corrective action prior to wet season. Consult engineers if immediate solution is not evident.		
General Maintenance Inspection	Visual observation	Visual observation	Annually, prior to start of wet season	Corrective action prior to wet season. Consult engineers if immediate solution is not evident.		

ATTACHMENT 3A – BMP MAINTENANCE PLAN - BIOFILTRATION BASIN

Erosion	Visual observation	Visual observation	Annually, prior to start of wet season	Corrective action prior to wet season. Consult engineers if immediate solution is not evident.		
Poor Vegetation Establishment	Visual observation	Visual observation	Annually, prior to start of wet season	Corrective action prior to wet season. Consult engineers if immediate solution is not evident.		

**ATTACHMENT 4**  
**Copy of Plan Sheets Showing Permanent Storm Water BMPs**

This is the cover sheet for Attachment 4.



**Use this checklist to ensure the required information has been included on the plans:**

The plans must identify:

- Structural BMP(s) with ID numbers matching Form I-6 Summary of PDP Structural BMPs
- The grading and drainage design shown on the plans must be consistent with the delineation of DMAs shown on the DMA exhibit
- Details and specifications for construction of structural BMP(s)
- Signage indicating the location and boundary of structural BMP(s) as required by the City Engineer
- How to access the structural BMP(s) to inspect and perform maintenance
- Features that are provided to facilitate inspection (e.g., observation ports, cleanouts, silt posts, or other features that allow the inspector to view necessary components of the structural BMP and compare to maintenance thresholds)
- Manufacturer and part number for proprietary parts of structural BMP(s) when applicable
- Maintenance thresholds specific to the structural BMP(s), with a location-specific frame of reference (e.g., level of accumulated materials that triggers removal of the materials, to be identified based on viewing marks on silt posts or measured with a survey rod with respect to a fixed benchmark within the BMP)
- Recommended equipment to perform maintenance
- When applicable, necessary special training or certification requirements for inspection and maintenance personnel such as confined space entry or hazardous waste management
- Include landscaping plan sheets showing vegetation requirements for vegetated structural BMP(s)
- All BMPs must be fully dimensioned on the plans
- When proprietary BMPs are used, site specific cross section with outflow, inflow and model number shall be provided. Broucher photocopies are not allowed.

ADDITIONAL DETAILS ARE PROVIDED IN SWQMP ATTACHMENT 1 AND CONSTRUCTION DRAWING LEVEL DETAILS WILL BE SHOWN ON FINAL DESIGN PHASE GRADING PLANS. THIS IS A CONCEPTUAL DESIGN TO SUPPORT ENTITLEMENTS ONLY.



# CONCEPTUAL GRADING AND UTILITY PLANS FOR OCEAN CREEK

## OWNER

THOMAS D. WEESE  
TRUSTEE OF THE ROBERT. A WEESE FAMILY TRUST,  
U/7/A DATED 12/23/78 TO AN UNDIVIDED ONE-HALF  
INTEREST, AND TOMAS D. WEESE, AS TRUSTEE UNDER  
THE BESSIE JANE WEESE TESTIMONY TRUST

## APPLICANT

OCEAN CREEK, LLC  
12250 EL CAMINO REAL  
SUITE 380  
SAN DIEGO, CA 92130  
(858) 369-5670

## SURVEY SOURCE

THE TOPOGRAPHIC MAPPING USED FOR THIS SURVEY IS BASED ON A FIELD SURVEY PERFORMED BY HUNSAKER & ASSOC. TOGETHER WITH AERIAL TOPOGRAPHY PRODUCED BY RJ LUNG PER FLIGHT OF DECEMBER 27, 2017. VERTICAL DATUM BASED ON NAVD 88 PER CITY OF OCEANSIDE BENCHMARK NO. 1013 PER RECORD OF SURVEY NO. 21787 EL=99.46.

## LEGEND

- RIGHT OF WAY
- PARCEL LINE
- STREET CENTERLINE
- EASEMENT
- PROPOSED SEWER
- LANDSLIDE LIMITS
- SEWER MANHOLE
- SEWER CLEANOUT
- PROPOSED FIRE WATER
- DOMESTIC WATER
- PROPOSED STORM DRAIN
- PROPOSED FIRE HYDRANT
- PROPOSED CONCRETE
- PROPOSED AC
- BIOFILTRATION BASIN
- UNDERGROUND CISTERN
- STORM DRAIN CLEANOUT
- STORM DRAIN INLET/CATCH BASIN
- SIDEWALK
- CURB AND GUTTER
- STREET TREE BMP PER COUNTY OF SAN DIEGO GREEN STREETS STANDARDS (SEE SWOMP FOR MORE INFORMATION)
- PROPOSED STREET LIGHT
- MODULAR WETLAND SYSTEM (MWS)
- POLLUTANT CONTROL BMP

## ABBREVIATIONS

- ADA - AMERICANS WITH DISABILITIES ACT
- BS - BOTTOM OF STAIRS
- CB - CATCH BASIN
- CY - CUBIC YARDS
- EX - EXISTING
- FF - FINISH FLOOR ELEVATION
- FG - FINISHED GRADE
- FH - FIRE HYDRANT
- FL - FLOW LINE
- FS - FINISHED SURFACE
- GB - GRADE BREAK
- IE - INVERT ELEVATION
- MWS - MODULAR WETLAND UNIT (SEE SWOMP)
- PVC - POLYVINYL CHLORIDE
- RCP - REINFORCED CONCRETE PIPE
- RM - RIM OF STRUCTURE ELEVATION
- R/W - RIGHT-OF-WAY
- SD - STORM DRAIN
- SDCO - STORM DRAIN CLEAN OUT
- SDRSD - SAN DIEGO REGIONAL STD DWG
- SF - SQUARE FEET
- SS - SANITARY SEWER
- SSCO - SANITARY SEWER CLEAN OUT
- S.T. - STREET TREE BMP
- TC - TOP OF CURB
- TD - TOP OF DITCH
- TF - TOP OF FOOTING
- TG - TOP OF GRADE
- TOB - TOP OF BASIN
- TS - TOP/TOE OF SLOPE
- TW - TOP OF WALL
- U.O.N. - UNLESS OTHERWISE NOTED
- WAS - WATER AGENCIES STANDARD
- WS - WATER SERVICE

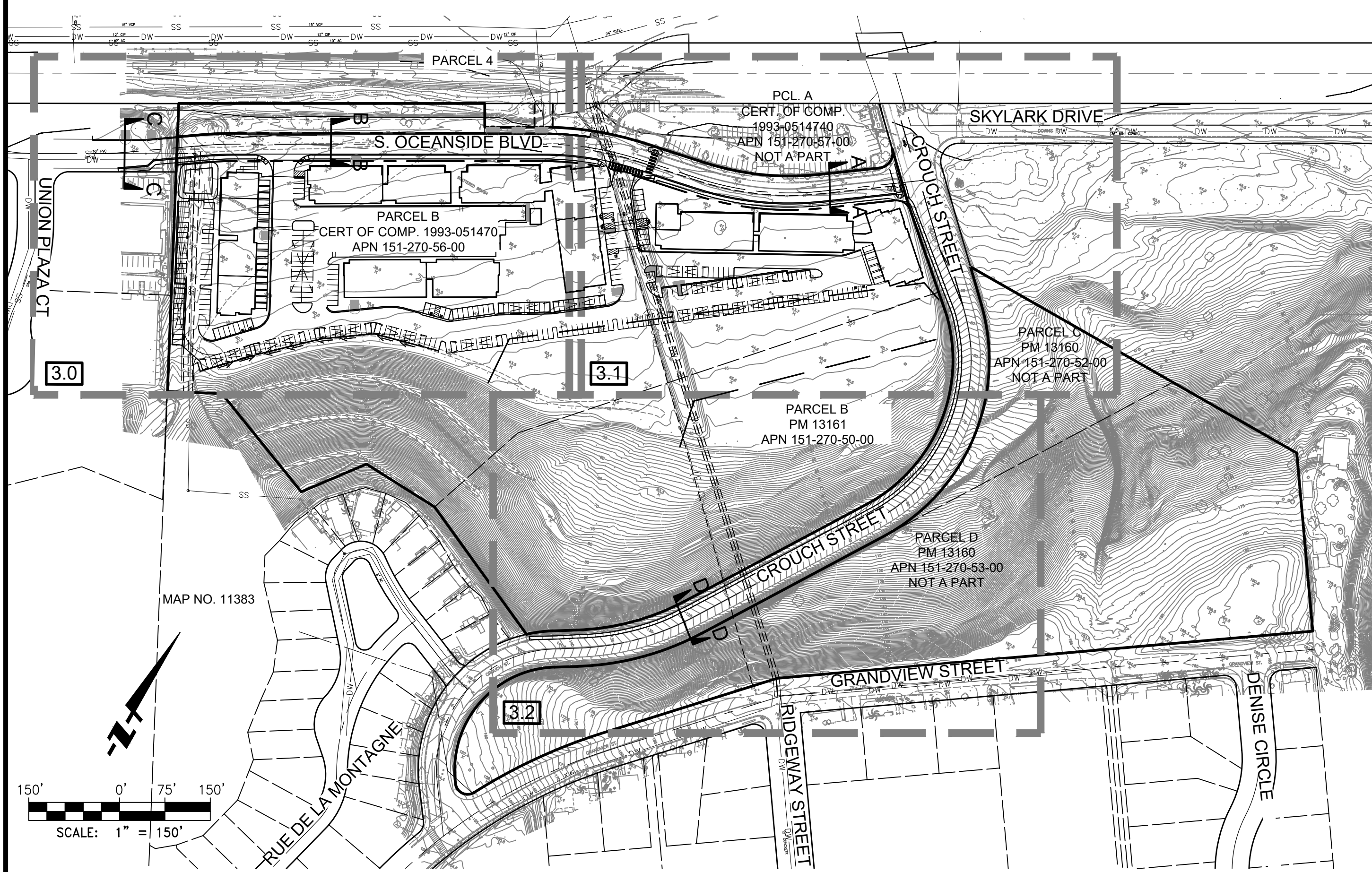

## KEY MAP LEGEND

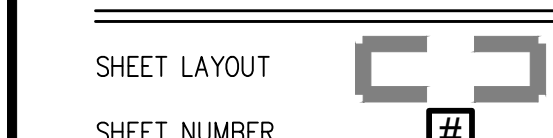

## SHEET INDEX

TITLE SHEET	SHEET C-1.0
EXISTING CONDITIONS	SHEET C-2.0
CONCEPTUAL GRADING AND UTILITIES	SHEET C-3.0
CONCEPTUAL GRADING AND UTILITIES	SHEET C-3.1
CONCEPTUAL GRADING AND UTILITIES	SHEET C-3.2

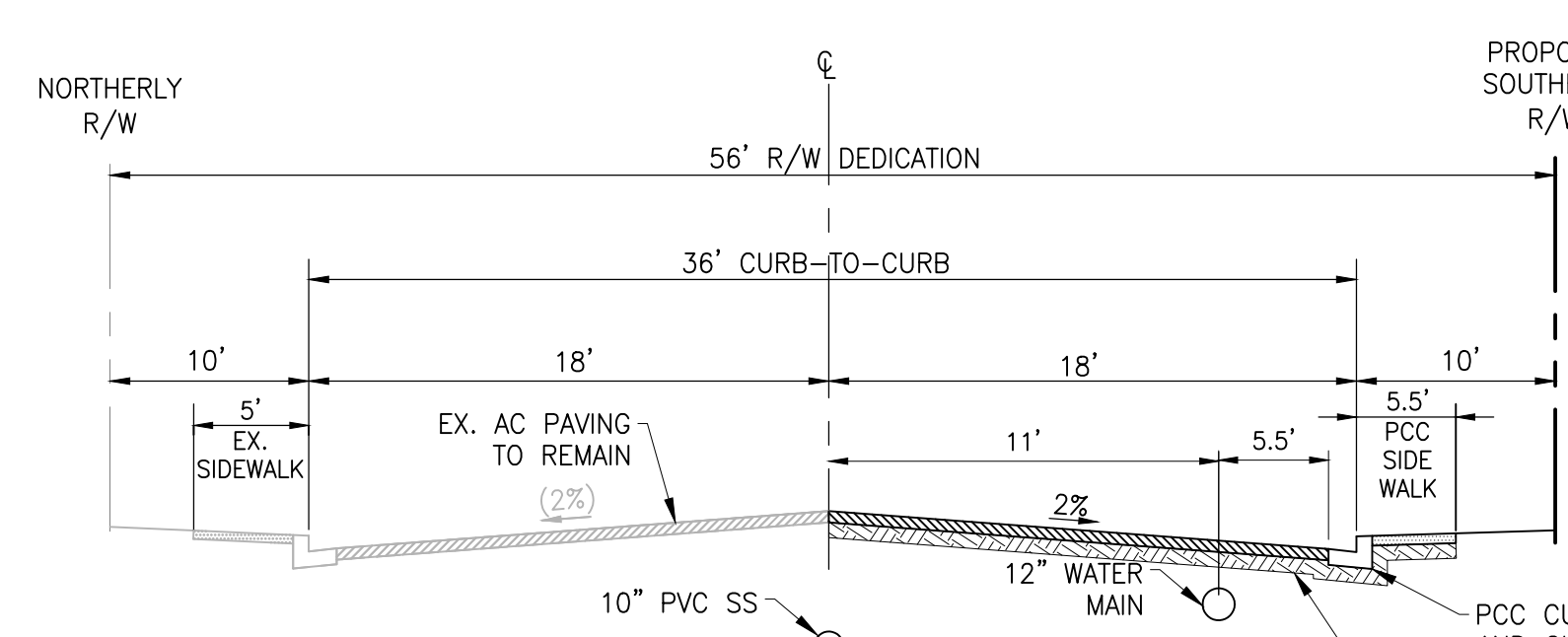

SECTION - S. OCEANSIDE BLVD.  
ADJACENT TO NCTD PROPERTY  
STA 11+24.66 - 17+41.17  
SCALE: N.T.S.

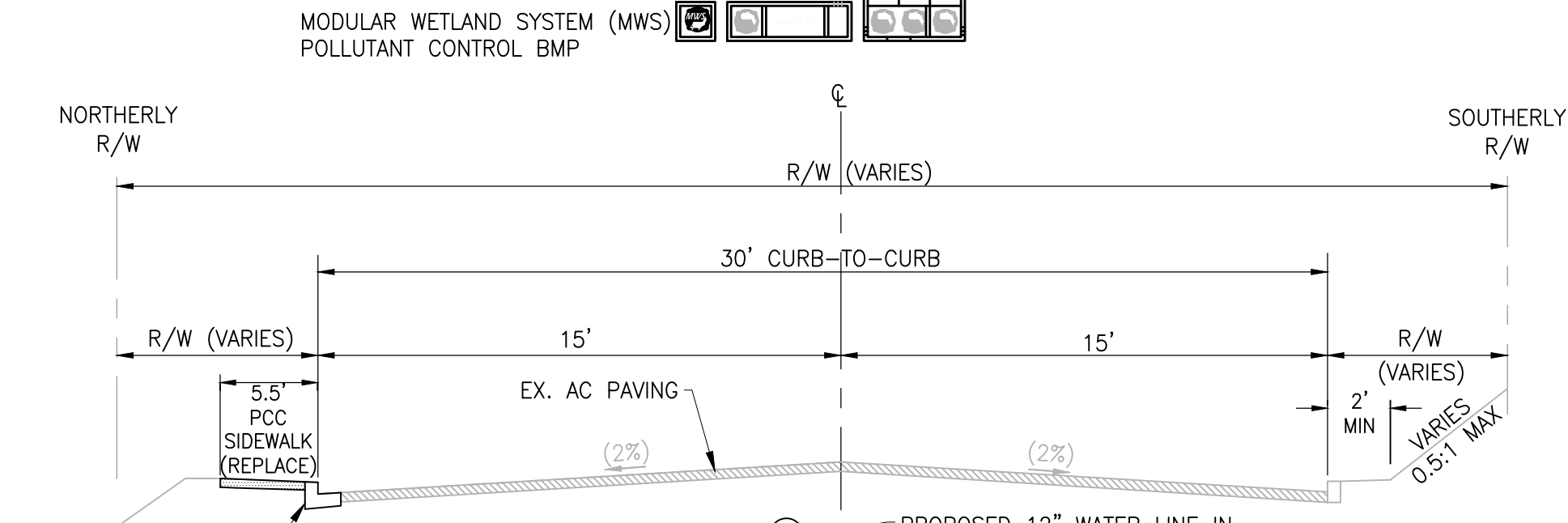

SECTION - CROUCH STREET  
SOUTH OF PROJECT PROPERTY  
SCALE: N.T.S.

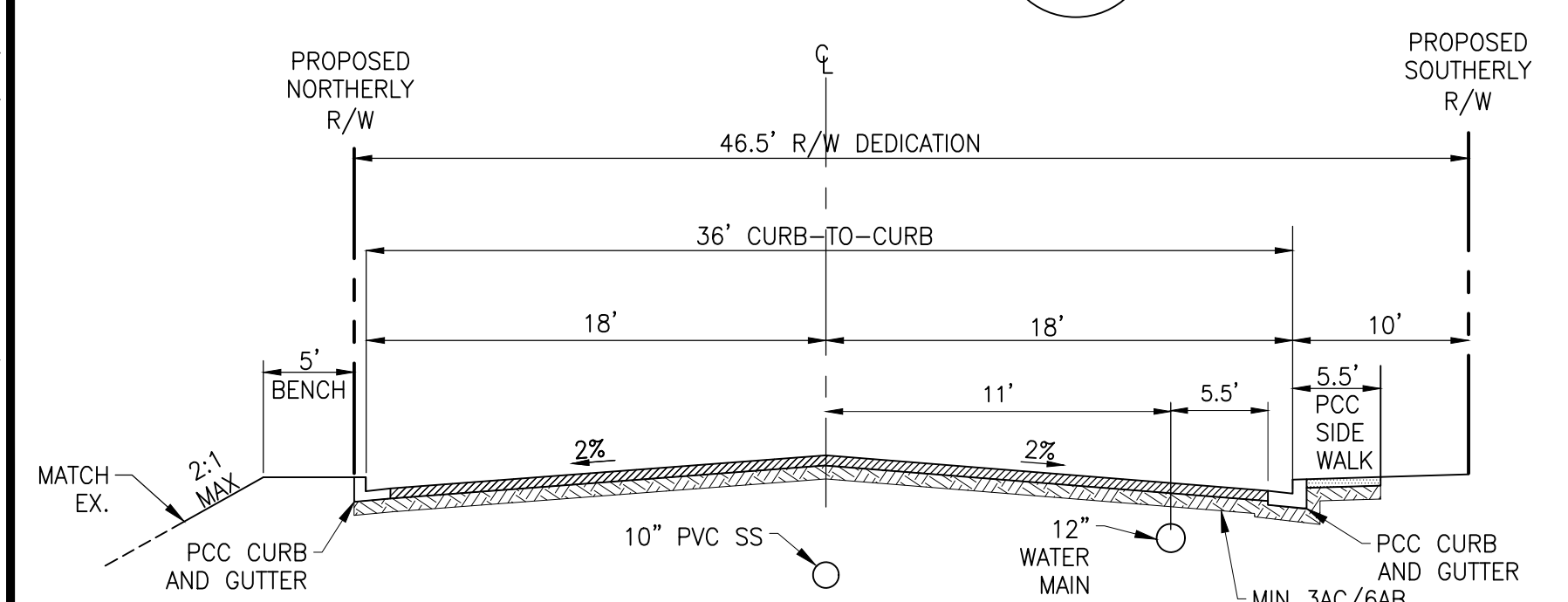

SECTION - S. OCEANSIDE BLVD.  
FROM WESTERN PL TO NCTD PROPERTY  
STA 17+41.17 - 22+49.80  
SCALE: N.T.S.

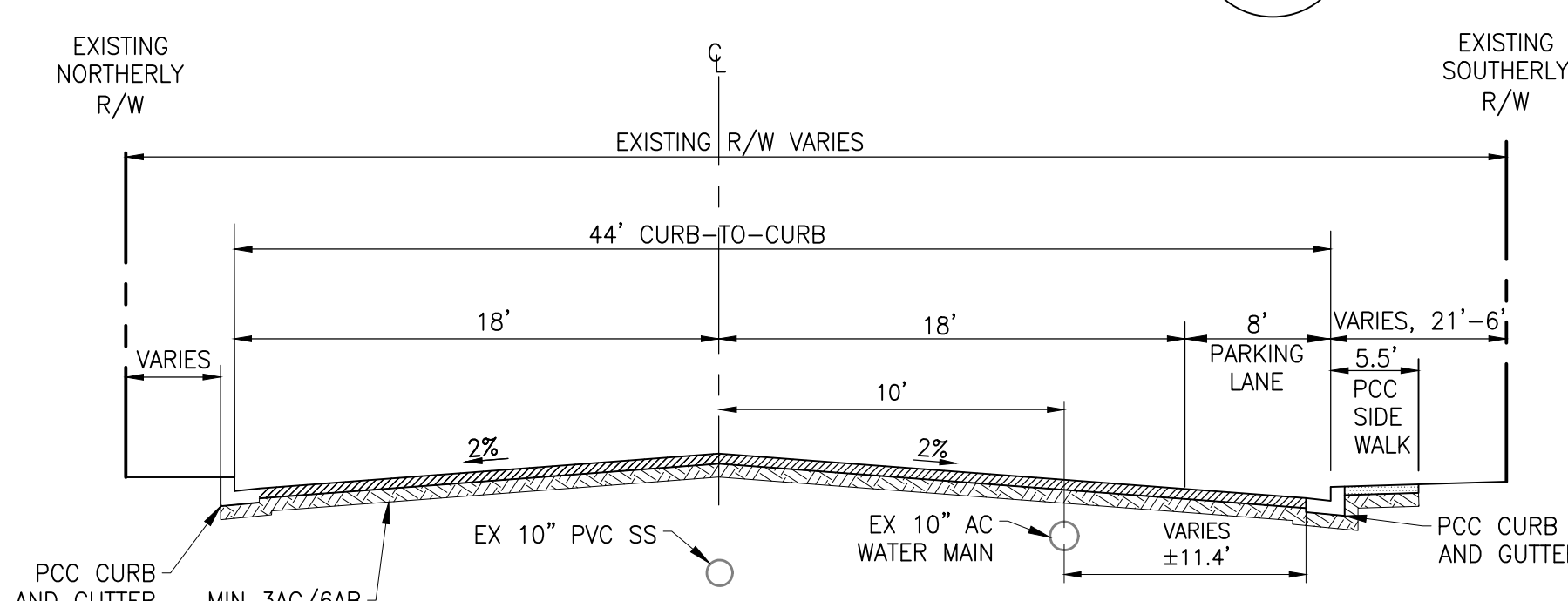

SECTION - S. OCEANSIDE BLVD.  
WEST OF PROJECT PROPERTY  
STA 22+49.80 - 23+89.84  
SCALE: N.T.S.

## ZONING

EXISTING ZONE: CC (COMMUNITY COMMERCIAL)

## PARCEL AREA

EXISTING: 2 PARCELS

APN	EX. NET AREA	R/W DEDICATION(-)/ VACATION(+)	PROP. NET AREA
151-270-56-00	12.87AC	- 1.65AC	11.22AC
151-270-50-00	5.98AC	0	5.98AC

## FLOOD ZONE

A PORTION OF THIS SITE IS LOCATED IN ZONE AE (BASE FLOOD ELEVATIONS DETERMINED) AS SHOWN ON THE FLOOD INSURANCE RATE MAP (F.I.R.M.), COMMUNITY-PANEL NO. 0607300753J, EFFECTIVE DATE: DECEMBER 20, 2019. A CLOMR WILL BE PROCESSED FOR IMPROVEMENTS WITHIN THE FLOODPLAIN AND FLOODWAY.

## UTILITIES

ELECTRIC - SDG&E  
GAS - SDG&E  
TELEPHONE - COX OR AT&T  
STORM DRAIN - OCEANSIDE WATER UTILITIES DEPARTMENT  
WATER - OCEANSIDE WATER UTILITIES DEPARTMENT  
SEWER - OCEANSIDE WATER UTILITIES DEPARTMENT

## EXISTING LEGAL DESCRIPTION

REAL PROPERTY IN THE CITY OF OCEANSIDE, COUNTY OF SAN DIEGO, STATE OF CALIFORNIA, DESCRIBED AS FOLLOWS:

APN: 151-270-56-00:

PARCEL "B" AS SHOWN ON CERTIFICATE OF COMPLIANCE NO. PLA-04-93 RECORDED AUGUST 9, 1993 AS INSTRUMENT NO. 93-0514740 OF OFFICIAL RECORDS, BEING MORE PARTICULARLY DESCRIBED AS FOLLOWS:

PARCEL A OF PARCEL MAP 13161, RECORDED: FEBRUARY 22, 1984, AS F/P 84-064016 OF OFFICIAL RECORDS OF SAN DIEGO COUNTY, BEING WITHIN THE CITY OF OCEANSIDE, COUNTY OF SAN DIEGO, STATE OF CALIFORNIA, EXCLUDING THAT PORTION BEING DESCRIBED AS FOLLOWS:

BEGINNING AT THE NORTHEASTERLY MOST CORNER OF SAID PARCEL "A"; THENCE SOUTHWESTERLY ALONG THE NORTHERLY LINE OF SAID PARCEL "A", SOUTH 59° 57' 17" WEST, 651.70 FEET (RECORD: SOUTH 59° 46' 47" WEST, P.M. 13161); THENCE LEAVING SAID NORTHERLY LINE, SOUTH 30° 02' 43" EAST, 39.22 FEET; THENCE PARALLEL WITH SAID NORTHERLY LINE OF PARCEL "A", NORTH 59° 57' 17" EAST, 96.00 FEET, TO THE BEGINNING OF A TANGENT 544.00 FOOT RADIUS CURVE, CONCAVE SOUTHEASTERLY, THENCE NORTHEASTERLY, ALONG THE ARC OF SAID CURVE, THROUGH A CENTRAL ANGLE OF 17° 51' 54", A DISTANCE OF 169.62 FEET; THENCE TANGENT TO SAID CURVE, NORTH 77° 49' 11" EAST, 106.22 FEET, TO THE BEGINNING OF A TANGENT 456.00 FOOT RADIUS CURVE, CONCAVE NORTHWESTERLY, THENCE NORTHEASTERLY ALONG THE ARC OF SAID CURVE, THROUGH A CENTRAL ANGLE OF 24° 00' 00", A DISTANCE OF 191.01 FEET; THENCE TANGENT TO SAID CURVE NORTH 53° 49' 11" EAST, 100 FEET, TO THE BEGINNING OF A TANGENT 25.00 FOOT RADIUS CURVE, CONCAVE NORTHWESTERLY, THENCE NORTHEASTERLY AND NORTHERLY ALONG THE ARC OF SAID CURVE, THROUGH A CENTRAL ANGLE OF 100° 00' 00", A DISTANCE OF 43.63 FEET, TO AN INTERSECTION WITH THE EASTERLY LINE OF THE ABOVE DESCRIBED PARCEL "A"; THENCE NORTHWESTERLY ALONG SAID EASTERLY LINE, AND TANGENT TO SAID CURVE, NORTH 46° 10' 49" WEST, 78 FEET, (RECORD: NORTH 46° 19' 24" WEST, P.M. 13161) TO THE POINT OF BEGINNING.

APN 151-270-50-00:

PARCEL B OF PARCEL MAP NO. 13161, IN THE CITY OF OCEANSIDE, COUNTY OF SAN DIEGO, STATE OF CALIFORNIA, FILED IN THE OFFICE OF THE COUNTY RECORDER OF SAN DIEGO COUNTY, FEBRUARY 22, 1984 AS INSTRUMENT NO. 84-064016 OF OFFICIAL RECORDS.

## GRADING QUANTITIES

TOTAL DISTURBED AREA:	9.91 AC
PROJECT MAX DEPTH OF CUT:	6 FT
PROJECT MAX DEPTH OF FILL:	4 FT
MAX CUT SLOPE RATIO:	2:1
MAX FILL SLOPE RATIO:	2:1

ON-SITE GRADING:	
DISTURBED AREA:	9.91 AC
AMOUNT OF CUT:	13,600 CY
AMOUNT OF FILL:	3,500 CY
AMOUNT OF EXPORT:	10,100 CY

GRADING QUANTITIES ARE APPROXIMATE AND SUBJECT TO CHANGE BASED ON FINAL DESIGN. QUANTITIES SHALL NOT BE USED FOR BIDDING PURPOSES.



architecture design collaborative  
23231 South Pointe Dr  
Laguna Hills, CA 92653  
www.adcollaborative.com  
949.267.1660

ADC Project No: 190147

Project Contact: Chris Weimholt  
Email: cweimholt@adcollaborative.com  
Principal: Chris Weimholt  
Project Manager:

## Client

Company: Ocean Creek, LLC  
Address: 12250 El Camino Real, Suite 380  
San Diego, CA 92130  
Phone No. (858) 699-7510

OCEAN CREEK, LLC

OCEANSIDE, CA

## Issue Date

1ST SUBMITTAL 03/09/2020

2ND SUBMITTAL 06/07/2021

3RD SUBMITTAL 09/01/2021

4TH SUBMITTAL 02/23/2022

## TITLE SHEET

C-1.0

F:\PROJECTS\25710\PLANS\CONCEPTUAL GRADING PLAN\597-010-CR0201TS.DWG By: Bryan Smith



6390 Greenwich Dr., Suite 170, San Diego, California 92122  
tel 858.554.1500 • fax 858.597.0335 • www.fuscoe.com

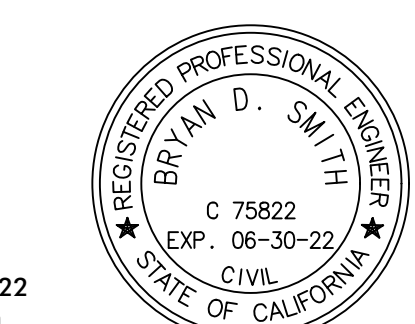

COPYRIGHT ©



architecture design collaborative  
 23231 South Pointe Dr  
 Laguna Hills, CA 92653  
 www.adcollaborative.com  
 949.267.1660

ADC Project No: 190147

Project Contact: Chris Weimholt  
 Email: cweimholt@adcollaborative.com  
 Principal: Chris Weimholt  
 Project Manager:

Client

Company: Ocean Creek, LLC  
 Address: 12250 El Camino Real, Suite 380  
 San Diego, CA 92130  
 Phone No. (858) 699-7510

**LEGEND**

RIGHT OF WAY	---
PROPERTY LINE	---
PARCEL LOT LINE	---
STREET CENTERLINE	---
EASEMENT	---
100-YR FLOODWAY	---
100-YR FLOOD PLAIN	---
LANDSLIDE LIMITS	---
EXISTING STORM DRAIN	---
EXISTING SEWER	---
EXISTING WATER	---
EXISTING OVERHEAD UTILITY	---

**EASEMENT NOTES**

- ⑧ AN EASEMENT FOR PUBLIC UTILITIES AND INCIDENTAL PURPOSES RECORDED JANUARY 30, 1934 AS BOOK 262, PAGE 435 OF OFFICIAL RECORDS. IN FAVOR OF: SAN DIEGO CONSOLIDATED GAS AND ELECTRIC COMPANY AFFECTS: PARCEL D OF PARCEL 1
- ⑩ AN EASEMENT FOR PUBLIC UTILITIES AND INCIDENTAL PURPOSES, RECORDED JUNE 7, 1954 AS BOOK 5261, PAGE 195 OF OFFICIAL RECORDS. IN FAVOR OF: CITY OF OCEANSIDE AFFECTS: PARCEL D OF PARCEL 1, PARCEL 2 AND PARCEL 3 TO BE QUITCLAIMED
- ⑪ AN EASEMENT FOR PUBLIC UTILITIES AND INCIDENTAL PURPOSES, RECORDED FEBRUARY 16, 1955 AS BOOK 5534, PAGE 585 OF OFFICIAL RECORDS. IN FAVOR OF: SAN DIEGO GAS AND ELECTRIC COMPANY AFFECTS: PARCEL D OF PARCEL 1, PARCEL 2 AND PARCEL 3 TO BE QUITCLAIMED
- ⑬ AN EASEMENT SHOWN OR DEDICATED ON THE MAP AS REFERRED TO IN THE LEGAL DESCRIPTION FOR: DRAINAGE CHANNEL RESERVATION PER LOT SPLIT MAP NO. 458 AND INCIDENTAL PURPOSES. AFFECTS: PARCEL 2
- ⑭ AN EASEMENT FOR PUBLIC UTILITIES AND INCIDENTAL PURPOSES, RECORDED DECEMBER 13, 1985 AS INSTRUMENT NO. 85-470870 OF OFFICIAL RECORDS. IN FAVOR OF: CITY OF OCEANSIDE AFFECTS: PARCEL 2
- ⑯ THE TERMS, PROVISIONS AND EASEMENT(S) CONTAINED IN THE DOCUMENT ENTITLED "AGREEMENT REGARDING ACCESS EASEMENT" RECORDED AUGUST 22, 2006 AS INSTRUMENT NO. 2006-0600028 OF OFFICIAL RECORDS. TO BE SUPERCEDED BY PUBLIC RIGHT-OF-WAY DEDICATION

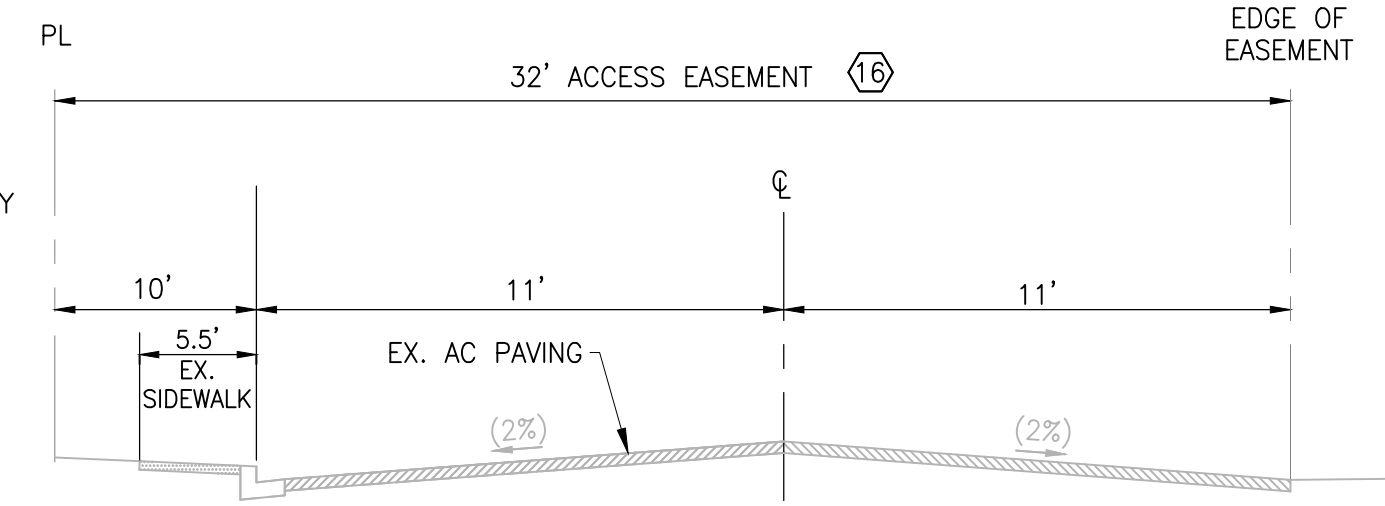
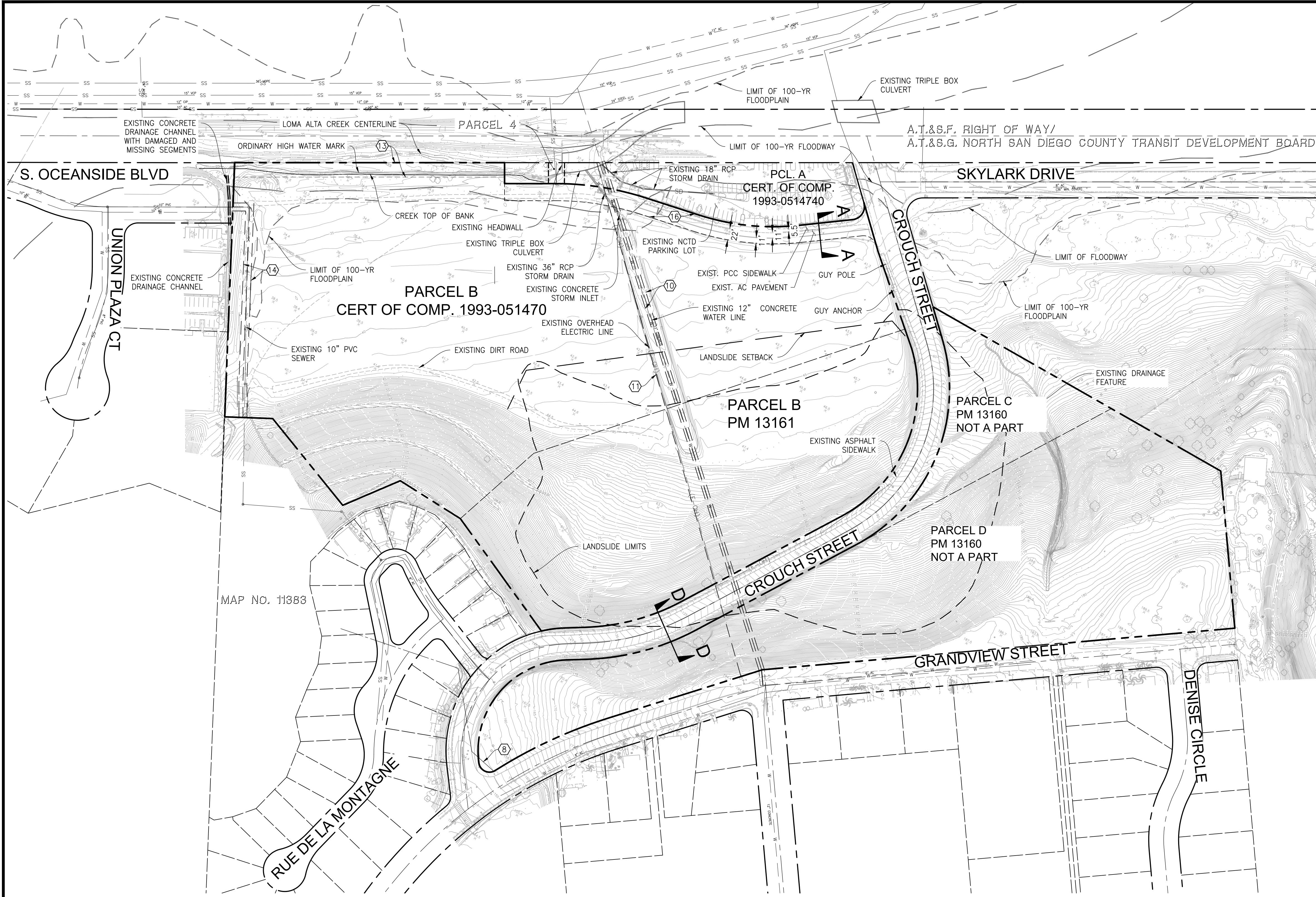

**SECTION - S. OCEANSIDE BLVD.  
 ADJACENT TO NCTD PROPERTY  
 STA 11+24.66 - 17+41.17**  
 SCALE: N.T.S.

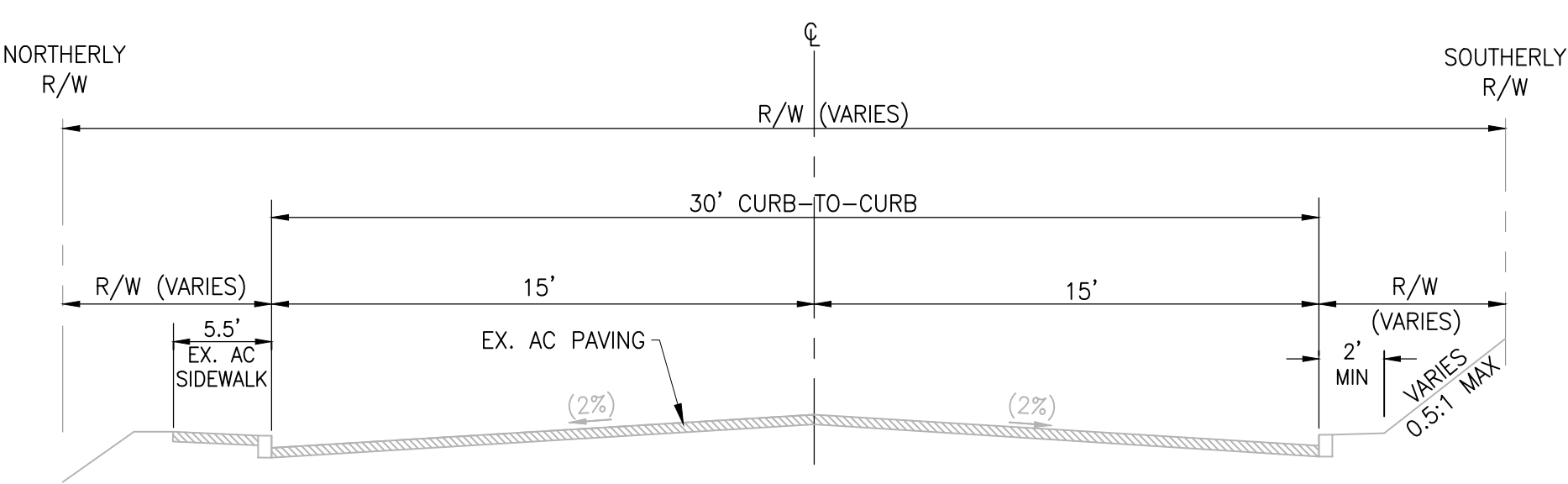

**SECTION - CROUCH STREET  
 SOUTH OF PROJECT PROPERTY**  
 SCALE: N.T.S.



NOTE: EXISTING CONDITIONS SHOWN ON THIS MAP ARE BASED ON SURVEY PROVIDED BY OTHERS (AS NOTED ON TITLE SHEET, "SURVEY SOURCE"). A SURVEY WAS NOT PREPARED UNDER RESPONSIBLE CHARGE OF ENGINEER OF RECORD OF THESE CONCEPTS PLANS

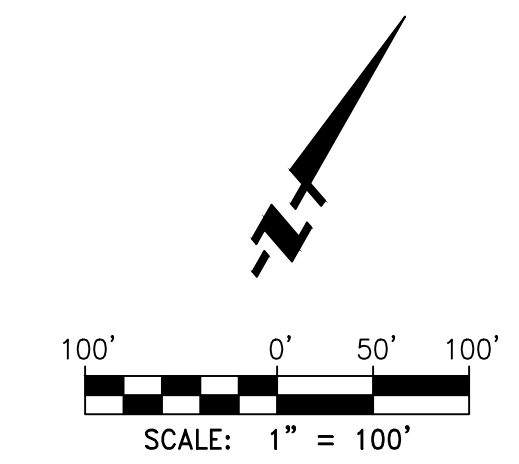

F:\PROJECTS\357\01\PLANS\CONCEPTUAL GRADING PLAN\357-01D-CR0202EX.DWG By: Bryan Smith



Issue Date

1ST SUBMITTAL 03/09/2020

2ND SUBMITTAL 06/07/2021

3RD SUBMITTAL 09/01/2021

4TH SUBMITTAL 02/23/2022

EXISTING  
 CONDITIONS

C-2.0

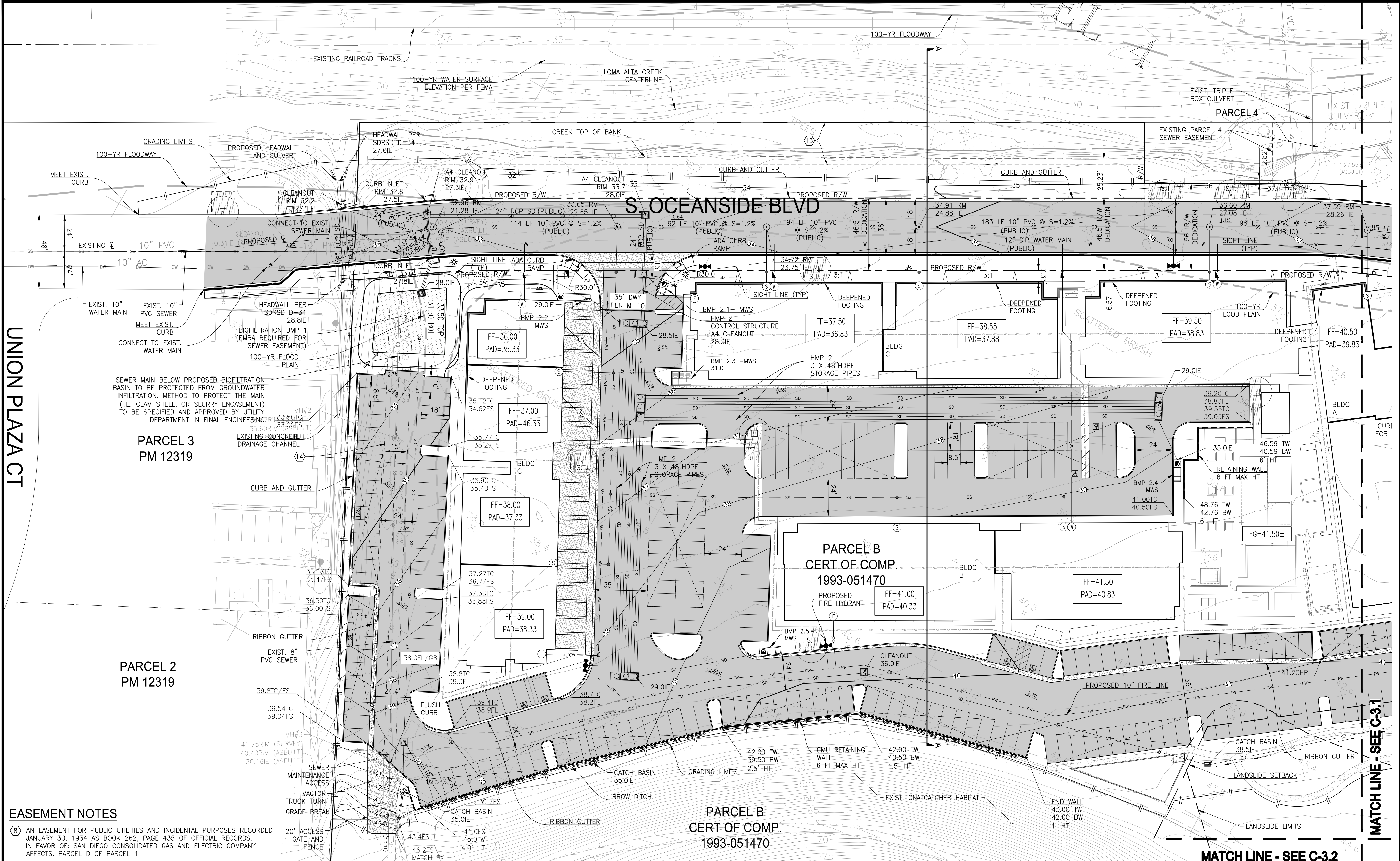

- EASEMENT NOTES**
- ⑧ AN EASEMENT FOR PUBLIC UTILITIES AND INCIDENTAL PURPOSES RECORDED JANUARY 30, 1934 AS BOOK 262, PAGE 435 OF OFFICIAL RECORDS. IN FAVOR OF: SAN DIEGO CONSOLIDATED GAS AND ELECTRIC COMPANY AFFECTS: PARCEL D OF PARCEL 1
  - ⑩ AN EASEMENT FOR PUBLIC UTILITIES AND INCIDENTAL PURPOSES, RECORDED JUNE 7, 1954 AS BOOK 5261, PAGE 195 OF OFFICIAL RECORDS. IN FAVOR OF: CITY OF OCEANSIDE AFFECTS: PARCEL D OF PARCEL 1, PARCEL 2 AND PARCEL 3 TO BE QUITCLAIMED
  - ⑪ AN EASEMENT FOR PUBLIC UTILITIES AND INCIDENTAL PURPOSES, RECORDED JUNE 7, 1954 AS BOOK 5261, PAGE 195 OF OFFICIAL RECORDS. IN FAVOR OF: CITY OF OCEANSIDE AFFECTS: PARCEL D OF PARCEL 1, PARCEL 2 AND PARCEL 3 TO BE QUITCLAIMED
  - ⑬ AN EASEMENT SHOWN OR DEDICATED ON THE MAP AS REFERRED TO IN THE LEGAL DESCRIPTION FOR: DRAINAGE CHANNEL RESERVATION PER LOT SPLIT MAP NO. 458 AND INCIDENTAL PURPOSES. AFFECTS: PARCEL 2
  - ⑭ AN EASEMENT FOR PUBLIC UTILITIES AND INCIDENTAL PURPOSES, RECORDED DECEMBER 13, 1985 AS INSTRUMENT NO. 85-470870 OF OFFICIAL RECORDS. IN FAVOR OF: CITY OF OCEANSIDE AFFECTS: PARCEL 2
  - ⑯ THE TERMS, PROVISIONS AND EASEMENT(S) CONTAINED IN THE DOCUMENT ENTITLED "AGREEMENT REGARDING ACCESS EASEMENT" RECORDED AUGUST 22, 2006 AS INSTRUMENT NO. 2006-0600028 OF OFFICIAL RECORDS. TO BE SUPERCEDED BY PUBLIC RIGHT-OF-WAY DEDICATION.

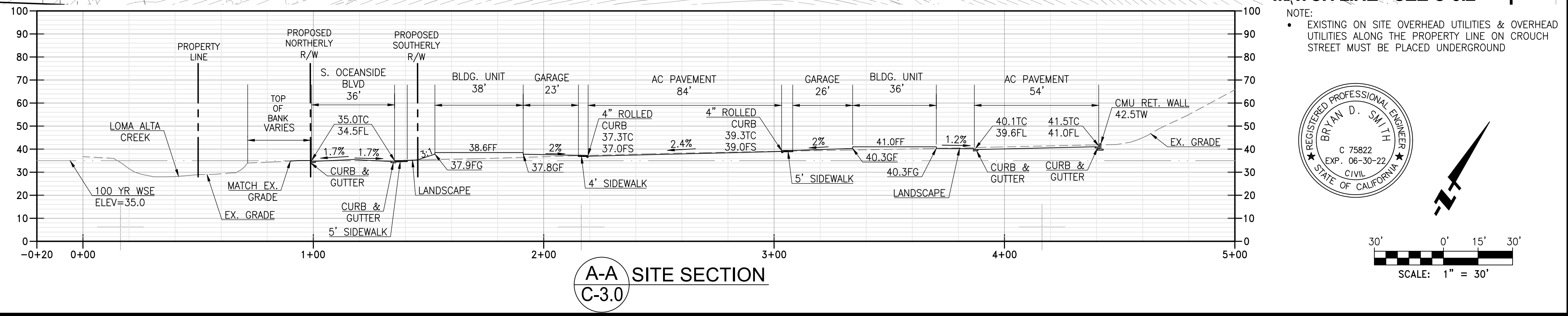

OCEAN CREEK, LLC  
 OCEANSIDE, CA

- Issue Date
- 1ST SUBMITTAL 03/09/2020
  - 2ND SUBMITTAL 06/07/2021
  - 3RD SUBMITTAL 09/01/2021
  - 4TH SUBMITTAL 02/23/2022

CONCEPTUAL  
 GRADING AND  
 UTILITIES

C-3.0

OCEAN CREEK, LLC  
 OCEANSIDE, CA

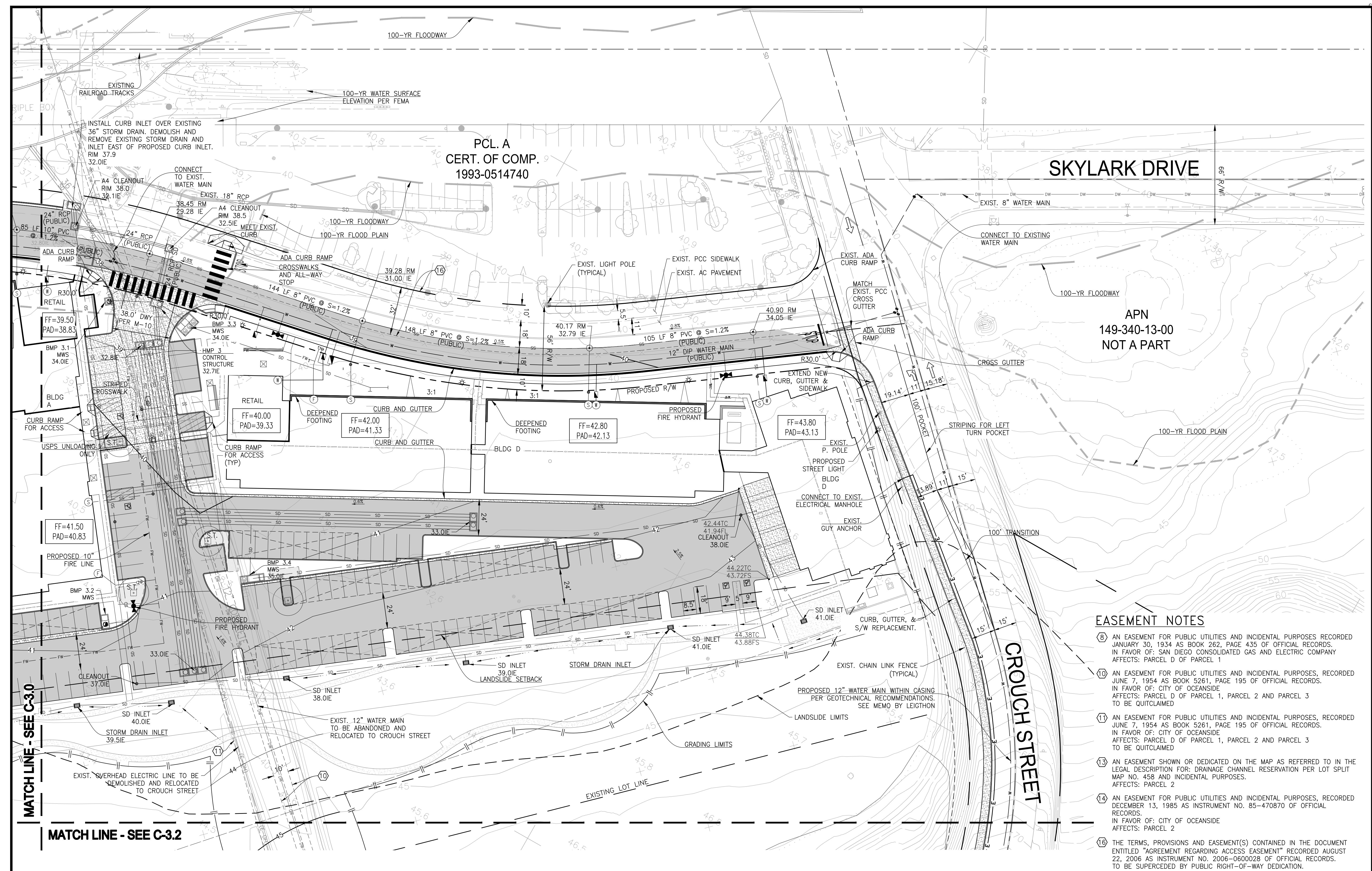

**EASEMENT NOTES**

- 8 AN EASEMENT FOR PUBLIC UTILITIES AND INCIDENTAL PURPOSES RECORDED JANUARY 30, 1934 AS BOOK 262, PAGE 435 OF OFFICIAL RECORDS. IN FAVOR OF: SAN DIEGO CONSOLIDATED GAS AND ELECTRIC COMPANY AFFECTS: PARCEL D OF PARCEL 1
- 10 AN EASEMENT FOR PUBLIC UTILITIES AND INCIDENTAL PURPOSES, RECORDED JUNE 7, 1954 AS BOOK 5261, PAGE 195 OF OFFICIAL RECORDS. IN FAVOR OF: CITY OF OCEANSIDE AFFECTS: PARCEL D OF PARCEL 1, PARCEL 2 AND PARCEL 3 TO BE QUITCLAIMED
- 11 AN EASEMENT FOR PUBLIC UTILITIES AND INCIDENTAL PURPOSES, RECORDED JUNE 7, 1954 AS BOOK 5261, PAGE 195 OF OFFICIAL RECORDS. IN FAVOR OF: CITY OF OCEANSIDE AFFECTS: PARCEL D OF PARCEL 1, PARCEL 2 AND PARCEL 3 TO BE QUITCLAIMED
- 13 AN EASEMENT SHOWN OR DEDICATED ON THE MAP AS REFERRED TO IN THE LEGAL DESCRIPTION FOR: DRAINAGE CHANNEL RESERVATION PER LOT SPLIT MAP NO. 458 AND INCIDENTAL PURPOSES. AFFECTS: PARCEL 2
- 14 AN EASEMENT FOR PUBLIC UTILITIES AND INCIDENTAL PURPOSES, RECORDED DECEMBER 13, 1985 AS INSTRUMENT NO. 85-470870 OF OFFICIAL RECORDS. IN FAVOR OF: CITY OF OCEANSIDE AFFECTS: PARCEL 2
- 16 THE TERMS, PROVISIONS AND EASEMENT(S) CONTAINED IN THE DOCUMENT ENTITLED "AGREEMENT REGARDING ACCESS EASEMENT" RECORDED AUGUST 22, 2006 AS INSTRUMENT NO. 2006-060028 OF OFFICIAL RECORDS. TO BE SUPERCEDED BY PUBLIC RIGHT-OF-WAY DEDICATION.



NOTE:  
 • EXISTING ON SITE OVERHEAD UTILITIES & OVERHEAD UTILITIES ALONG THE PROPERTY LINE ON CROUCH STREET MUST BE PLACED UNDERGROUND

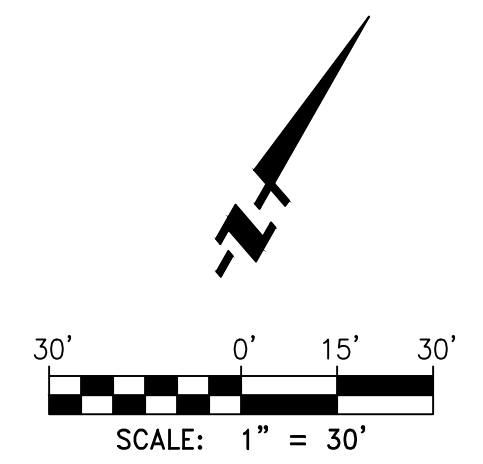

Issue Date
1ST SUBMITTAL 03/09/2020
2ND SUBMITTAL 06/07/2021
3RD SUBMITTAL 09/01/2021
4TH SUBMITTAL 02/23/2022



**ATTACHMENT 5  
Drainage Report**

This is the cover sheet for Attachment 5.





DRAINAGE STUDY

# JEFFERSON OCEANSIDE

PREPARED FOR

JPI DEVELOPMENT COMPANY  
12250 EL CAMINO REAL, SUITE 380  
SAN DIEGO, CA 92130

PREPARED BY

FUSCOE ENGINEERING, INC.  
6390 GREENWICH DR. STE: 170  
SAN DIEGO, CA 92122

PROJECT MANAGER

BRYAN D. SMITH

DATE PREPARED: MARCH 2020

REVISED: FEB. 2022

# PRELIMINARY DRAINAGE STUDY

## JEFFERSON OCEANSIDE

OCEANSIDE, CA

APN#  
151-270-50-00  
151-270-56-00

Prepared by Brittany Ciauri and Diane Manibo Under the Responsible Charge of:

---

Craig S. Watson, PE

RCE 79574

EXP: 09-30-2022

Fuscoe Engineering, San Diego, Inc.  
6390 Greenwich Dr., Ste 170 San Diego, CA 92122  
858-554-1500  
cwatson@fuscoe.com

For

JPI Development Company  
12250 El Camino Real, Suite 380  
San Diego, CA 92130

FEBRUARY 24, 2022



---

## TABLE OF CONTENTS

1.	INTRODUCTION .....	1
1.1	Project Description.....	1
1.2	Existing Conditions.....	2
1.3	Proposed Conditions.....	3
2.	METHODOLOGY .....	5
2.1	Rational Method .....	5
2.2	Computing Detention Pond Routing .....	6
2.3	Runoff Coefficient .....	7
2.4	Rainfall Intensity.....	7
2.5	Tributary Areas .....	7
2.6	Stage Storage .....	7
3.	CALCULATIONS/RESULTS .....	8
3.1	Peak Flow Comparison .....	8
3.2	Public Storm Drain.....	8
4.	CONCLUSION .....	9
	<b>Appendix 1.....Existing &amp; Proposed Conditions Hydrology Maps</b>	
	<b>Appendix 2..... Conceptual Grading and Utilities Plans</b>	
	<b>Appendix 3..... Existing Hydrology Calculations</b>	
	<b>Appendix 4.....Proposed Hydrology Calculations</b>	
	<b>Appendix 5.....FEMA Flood Map</b>	
	<b>Appendix 6.....FEMA Letters of Map Revision</b>	
	<b>Appendix 7.....Hydrographs, Storage Curves &amp; Inflow Hydrograph Inputs</b>	
	<b>Appendix 8.....Aggregate Storage Volume Calculations</b>	
	<b>Appendix 9.....CCSYA Bypass Velocity Calculation</b>	
	<b>Appendix 10.....San Diego County 100-year Isopluvial Map</b>	
	<b>Appendix 11.....Hydraulic Analysis for Jefferson Oceanside</b>	

# 1. INTRODUCTION

The purpose of this preliminary drainage study is to present the preliminary drainage design for entitlement purposes for the Jefferson Oceanside Project (Project) and to demonstrate that the project will comply with the San Diego County Hydrology Manual (June 2003) Criteria, City of Oceanside Drainage Ordinance, FEMA and Army Corp and other applicable agencies.

## 1.1 Project Description

The project proposes entitlements for a mixed-use, transit-oriented development on 18.85 gross acre site located southwest of the existing North County Transit District (NCTD) Crouch Street Sprinter Station. The site is bordered by Oceanside Boulevard to the north, Crouch Street to the east and south, and office development and S. Oceanside Boulevard to the west. The proposed development will consist of 295 dwelling units and approximately 3,000 sf of retail space. The proposed project will also include the extension of existing S. Oceanside Boulevard east to Crouch Street.

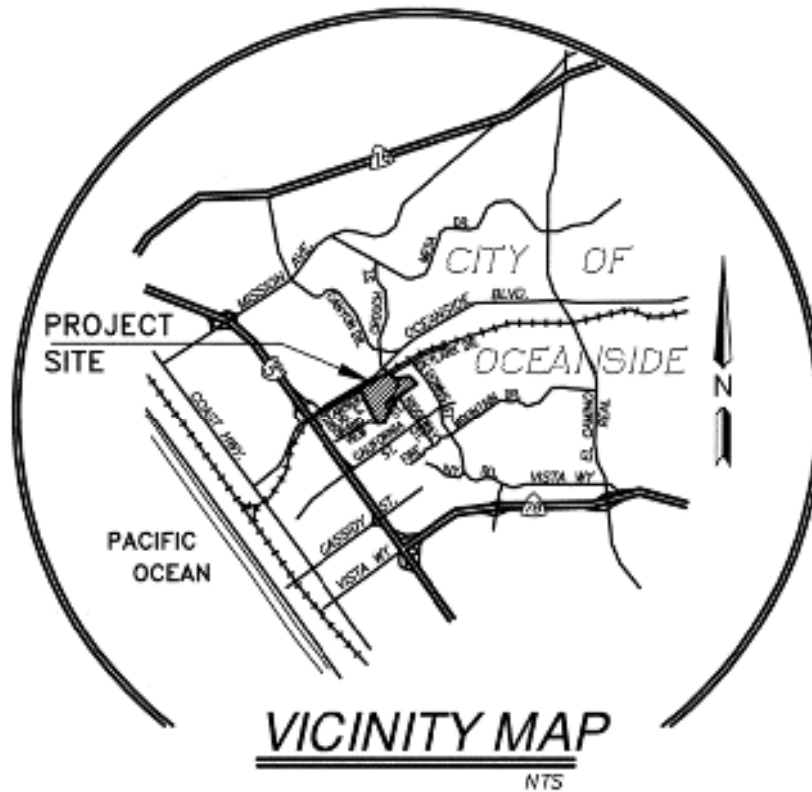

Figure 1. Vicinity Map

## 1.2 Existing Conditions

The project site in existing conditions is a vacant, previously graded lot south of the Loma Alta Creek and existing NCTD Crouch Street Sprinter Station. The site was previously graded in 1985 and slopes in the northwesterly direction, having an average slope of 2%. The southern portion of the site adjacent to Crouch Street is a historic landslide and consists of steep slopes. The project site is bisected by utility easements for overhead electrical and a 12-inch water main. An existing sewer easement is located at the western edge of the property. The site is accessed by an existing unnamed road west of Crouch Street, which also provides access to the NCTD Sprinter Station. A portion of the site along the northern property boundary is located within the FEMA 100-year Floodplain and Floodway. The existing storm drain system within the NCTD parking lot is owned by NCTD.

Stormwater runoff from the site consists primarily of sheet flow that drains north where it confluences and discharges to the Loma Alta Creek at two separate locations (Identified as Nodes 300 & 400).

The eastern portion of the site (identified as the 300 series) consists primarily of sheet flow that drains north to an existing headwall located within the easement at the center of the site. Stormwater is then conveyed north in the existing 36-inch public storm drain and discharges to the existing triple box culvert (Loma Alta Creek) located north of the project site. There is also an 18-inch RCP public storm drain pipe that discharges runoff from the offsite Sprinter Station parking lot north of the site to the existing triple box culvert.

Drainage from the existing unnamed roadway located north of the site (identified as node 300) flows west to a curb inlet located at the end of the unnamed road. The existing curb inlet drains to the existing 36-inch public storm identified above.

The western portion of the site (identified as the 400 series) sheet flows northwest to an existing concrete lined channel located at the east end of S. Oceanside Blvd. Off-site drainage from the neighborhoods located to the south of the project (also included in the 400 series) drains northwest where it confluences with onsite runoff in the existing concrete lined channel that discharges to the Loma Alta Creek (identified as Node 400). Node 400 also includes additional runoff from S. Oceanside Blvd. and Union Plaza Ct. The 400 series also includes runoff from the slope which is conveyed to the bottom of the slope via terrace ditches.

### 1.3 Proposed Conditions

The proposed mixed-use, transit-oriented development will consist of 295 dwelling units, approximately 3,000 SF of commercial/office and commercial/retail space, and associated amenity spaces. The existing access road from Crouch Street will be extended and connect to S. Oceanside Boulevard west of the property boundary. S. Oceanside Boulevard will become a dedicated public street with right-of-way widths as noted on the plans. The extension of S. Oceanside Blvd. will also include the addition of public storm drain, water, & sewer improvements.

The project is located within the FEMA 100-year Floodplain and Floodway (Zone AE), per FEMA FIRM Map Number 06073C0753J (refer to Appendix 5). The proposed building finished floor elevations have been set a minimum of 2 feet above the 100-year flood base elevations per County of San Diego Hydrology requirements. A Conditional Letter of Map Revision (CLOMR) will be required to be processed with FEMA. Refer to Appendix 6 for previous FEMA Letter of Map Revisions (LOMR).

The project will maintain existing drainage patterns to the maximum extent practical. As in existing conditions, stormwater runoff from the proposed development will ultimately discharge to the Loma Alta Creek located north of the property boundary and will maintain the two discharge points.

The east half of the site identified as series 300 consists of drainage from portions of the existing unimproved slope to the south of the site and onsite drainage. Offsite drainage from the southern unimproved slopes sheet flows north where it will be collected along the southern boundary of the project in a series of inlets. Offsite stormwater will be conveyed north through the site via private storm drain and discharge to the proposed 18-inch RCP public storm drain system located within S. Oceanside Blvd.

Onsite drainage within series 300 consists of sheet flow and mild concentrated flows that drain north/northwest, having an average slope of 1-2%. Onsite storm water runoff is conveyed to a series of inlets that collect and convey storm water runoff through proprietary treatment control BMPs. Stormwater from the proprietary treatment control BMP's drain to a central onsite underground detention system for hydromodification and 100-year peak flow attenuation. Storm water is then conveyed north via a 24-inch RCP pipe to the proposed public storm drain system. The public storm drain continues north/northwest and discharges to the existing curb inlet located on the north side of S. Oceanside Blvd.

The north half of S. Oceanside Blvd., also included in series 300, maintains existing drainage patterns and drains west to an existing curb inlet where it is collected and confluences with drainage from the proposed project. Stormwater is then conveyed north in the existing 36-inch public storm drain and discharges to the existing triple box culvert (Loma Alta Creek) located north of the project site.

Off-site drainage from the neighborhoods and existing slopes located to the south of the project (identified as series 400) maintain existing drainage patterns as outlined in Section 1.2. Runoff from the areas to the south of the project will be collected along the southern boundary of the project in a series of inlets. Offsite stormwater will be conveyed north through the site via private storm drain and discharge to the proposed public storm drain system located within S. Oceanside Blvd.

Onsite drainage for the west half of the project is also included in series 400 and is broken into two drainage areas for storm water treatment purposes. Onsite drainage for both areas consists of sheet flow and mild concentrated flows that drain north/northwest, having an average slope of 1-2%. The

---

west half of series 400 drains to a proposed biofiltration planter for stormwater treatment and 100-yr peak flow attenuation. The east half of series 400 drains to a series of inlets that collect and convey storm water runoff through proprietary treatment control BMPs. Stormwater from the proprietary treatment control BMP's drain to a central onsite underground detention system for hydromodification and 100-year peak flow attenuation. Storm water is then conveyed north via 24-inch RCP to the proposed public storm drain system.

The proposed extension of S. Oceanside Blvd. is located primarily within series 400. The majority of S. Oceanside Blvd. drains west towards the northwest corner of the project where it is collected by two proposed curb inlets located on the north and south side of S. Oceanside Blvd. Additional runoff from S. Oceanside Blvd. and Union Plaza Ct. from west of the project is also conveyed to these curb inlets.

The areas outlined above that are tributary to the 400 series node are all conveyed to S. Oceanside Blvd. to the northwest corner of the project/property boundary where they ultimately confluence within the proposed public storm drain system. All proposed storm drain in the public right of way will have a diameter of 18-inch or greater. The project proposes to remove a portion of the existing concrete lined channel located within the proposed right-of-way and construct a proposed 2-ft x 4-ft box culvert and headwall. The channel is located within the flood way and therefore any changes require FEMA and Army Corp approval. The proposed box culvert will convey runoff from the 400 series node and discharge to Loma Alta Creek.

The project will not result in increased 100-yr peak flow rates in the proposed condition after mitigation of the 100-year runoff. As shown in section 3.1 of this report, the Proposed-Mitigated 100-yr peak discharge is 86.89 cfs which is less than the Existing 100-yr discharge of 96.66 cfs. This was accomplished by running stage storage analysis on both HMP 1 and HMP 2. The proposed project is not anticipated to negatively affect the downstream facilities compared to existing conditions. The project proposes work within the floodplain and floodway and a Hydraulic Analysis demonstrating the project impacts has been prepared by Chang Consultants, dated 2/15/2022, see Appendix 11.

## 2. METHODOLOGY

### 2.1 Rational Method

Runoff was calculated using the Modified Rational Method equation below:

$$Q = C \times I \times A$$

Where:

Q = Flow rate in cubic feet per second (cfs)

C = Runoff coefficient

I = Rainfall Intensity in inches per hour (in/hr)

A = Drainage basin area in acres, (ac)

Modified Rational Method calculations were performed using the Advanced Engineering Software AES (2014) computer program. To perform the hydrology routing, the total watershed area was divided into sub-areas which discharge at designated nodes. The procedure for the sub-area summation model is as follows:

- (1) Subdivide the watershed into an initial sub-area (generally 1 lot) and subsequent sub- areas, which are generally less than 10 acres in size. Assign upstream and downstream node numbers to each sub-area.
- (2) Estimate an initial  $T_c$  by using the appropriate nomograph or overland flow velocity estimation. The minimum  $T_c$  considered is 5.0 minutes.
- (3) Using the initial  $T_c$ , determine the corresponding values of I. Then  $Q = CIA$ .
- (4) Using Q, estimate the travel time between this node and the next by Manning's equation as applied to particular channel or conduit linking the two nodes. Then, repeat the calculation for Q based on the revised intensity (which is a function of the revised time of concentration)

The nodes are joined together by links, which may be street gutter flows, drainage swales, drainage ditches, pipe flow, or various channel flows. The AES 2014 computer software sub-area menu is as follows:

#### SUBAREA HYDROLOGIC PROCESS

1. Confluence analysis at node.
  2. Initial sub-area analysis (including time of concentration calculation).
  3. Pipe flow travel time (computer estimated).
  4. Pipe flow travel time (user specified).
  5. Trapezoidal channel travel time.
  6. Street flow analysis through sub-area.
  7. User-specified information at node.
  8. Addition of sub-area runoff to main line.
  9. V-gutter flow through area.
  10. Copy main stream data to memory bank
  11. Confluence main stream data with a memory bank
-

## 12. Clear a memory bank

At the confluence point of two or more basins, the following procedure is used to combine peak flow rates to account for differences in the basin's times of concentration. This adjustment is based on the assumption that each basin's hydrographs are triangular in shape.

(1). If the collection streams have the same times of concentration, then the Q values are directly summed,

$$Q_p = Q_a + Q_b; T_p = T_a = T_b$$

(2). If the collection streams have different times of concentration, the smaller of the tributary Q values may be adjusted as follows:

(i). The most frequent case is where the collection stream with the longer time of concentration has the larger Q. The smaller Q value is adjusted by a ratio of rainfall intensities.

$$Q_p = Q_b + Q_a (I_b/I_a); T_p = T_a$$

(ii). In some cases, the collection stream with the shorter time of concentration has the larger Q. Then the smaller Q is adjusted by a ratio of the T values.

$$Q_p = Q_b + Q_a (T_b/T_a); T_p = T_b$$

## 2.2 Computing Detention Pond Routing

Detention pond routing is the process of passing a flood hydrograph through a storage reservoir or detention pond. This process changes the pattern of flow with respect to time but conserves volume. The purpose of detention pond routing is usually to reduce the peak flow to a predetermined level, or to delay the peak. The routing procedure used by Hydraflow Hydrographs Extension is known as the Storage Indication method and begins with a stage- storage-discharge relationship, an inflow hydrograph, and the following equation:

$$I - O = \frac{ds}{dt}$$

Where:

I = inflow

O =

outflow

ds/dt = change in storage

## **2.3 Runoff Coefficient**

The runoff coefficient for the project was calculated using Table 3-1: Runoff Coefficients for Urban Areas, of the 2003 San Diego County Hydrology Manual, and the corresponding percentage of impervious surface for each tributary area. The site contains Hydrologic Soil Group D soils and has a runoff coefficient of 0.35.

## **2.4 Rainfall Intensity**

Rainfall intensity was determined by using AES software, which utilizes Figure 3-2: Rainfall Intensity-Duration Design Chart of the San Diego County Hydrology Manual, see Appendix 10.

## **2.5 Tributary Areas**

Drainage basins are delineated on the Existing and Proposed Hydrology Condition Maps in Appendix 1.

## **2.6 Stage Storage**

Hydraflow Hydrograph by Autodesk was used to perform stage storage detention basin routing of the underground detention systems (HMP 1 and HMP 2). The two underground detention systems were modeled to determine the volume capacity and peak flow attenuations of the basins during a 100-year storm event. See Appendix 7 for basin routing calculations.

The underground detention system outflows obtained from Hydraflow were used in the AES mitigated conditions to analyze the total cumulative flow at Nodes 300 & 400. 100-year storm attenuation was performed for HMP 1 and HMP 2.

### 3. CALCULATIONS/RESULTS

#### 3.1 Peak Flow Comparison

The summary tables below present the comparison between pre- and post-development flows for each point of compliance. The proposed flow rates do not reflect the stage storage analysis for the underground detention system. The onsite underground detention system and biofiltration planter were oversized for water quality and hydromodification by approximately 20-30% to attenuate the 100-yr storm event. Stage storage calculations will be provided when construction drawings are prepared.

PRE-DEVELOPMENT CONDITIONS HYDROLOGY SUMMARY		
NODE	AREA (AC)	EXISTING 100-YEAR DISCHARGE (CFS)
300	6.59	11.64
400	50.07	78.39
TOTAL	61.58	90.03

POST-DEVELOPMENT CONDITIONS HYDROLOGY SUMMARY		
		100-YEAR DISCHARGE (CFS)
NODE	AREA (AC)	PROPOSED – UNMITIGATED
300	6.53	15.61
400	49.64	81.05
TOTAL	61.05	96.66

POST-DEVELOPMENT CONDITIONS HYDROLOGY SUMMARY		
		100-YEAR DISCHARGE (CFS)
NODE	AREA (AC)	PROPOSED – MITIGATED
300	6.53	9.39
400	49.64	77.50
TOTAL	61.05	86.89

#### 3.2 Public Storm Drain

A hydraulic analysis using FlowMaster was performed to size the proposed public storm drain box culvert in S. Oceanside Blvd. See Appendix 4 for the results.

## 4. CONCLUSION

The project will match existing drainage patterns to the maximum extent feasible and will utilize the existing discharge points to Loma Alta Creek. The project will result in a decrease in 100-year peak flow rates after mitigating the 100-year runoff compared to existing conditions. This was accomplished by running stage storage analysis on both HMP 1 and HMP 2. The proposed project is not anticipated to have any adverse effect on the downstream facilities, including Loma Alta Creek, compared to that of existing conditions. The building finished floor elevations will be set at a minimum 2ft above the FEMA 100-year water surface elevation. A Conditional Letter of Map Revision (CLOMR) will be required to be processed with FEMA.